



Series 725

Self-Contained Flake Ice Machine



Features:

- Great performance
- Quality flake ice
- Production up to 600 lb (273 kg) per day
- Bin capacity 300 lb (136 kg)
- Environmentally safe
- R404a Refrigerant
- Energy efficient - lower cost - long life
- Continuous ice making
- One single moving part
- Top mounted drive system
- Compact space saving design
- Low profile
- Gray baked enamel exterior
- Polyethylene bin



Series 725

Technical Specifications:

Condenser: Air-cooled

Shipping Weight: 334 lb (152 kg)

Water pressure: 20-120 psi

Ice Storage Capacity: 300 lb (136 kg)

Circuit Capacity: 20A

Maximum fuse size: 20A

Operating Weight: 300 lb (136 kg)

Refrigerant type: R-404a

Ambient temperature: 50°F (10°C) -100°F (38°C)

Water temperature: 50°F (10°C) - 90°F (32°C)

Agency Listings:

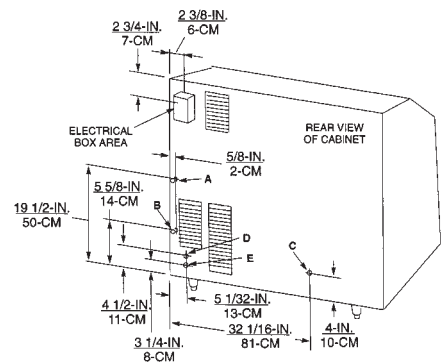
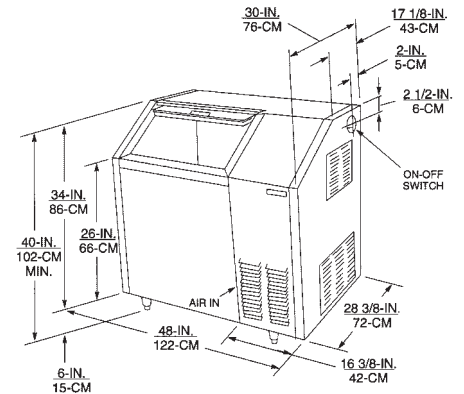

- A – 3/8 WATER INLET (S.A.E. MALE FLARE)
- B – 1/2 O.D. TUBE (CONDENSATE DRAIN)
- C – 3/4 N.P.T. BIN DRAIN
- D – CONDENSER WATER IN (W/C ONLY)
- E – CONDENSER WATER OUT (W/C ONLY)

AF-725-P(S)-SCR PRODUCTION CHART			
AIR TEMPERATURE	WATER TEMPERATURE		
	50°F/10°C	70°F/21°C	80°F/27°C
50°F/10°C	654 lb/297 kg	588 lb/267 kg	552 lb/251 kg
70°F/21°C	639 lb/290 kg	563 lb/256 kg	521 lb/237 kg
90°F/32°C	562 lb/255 kg	479 lb/218 kg	448 lb/204 kg

Model No.	Description	Cabinet	Electrical/	Voltage
AF725-P-SCR	725 Self-Contained Flaker	Enamel	115V/60Hz/1	110-126V
AF725-S-SCR	725 Self-Contained Flaker	Stainless	115V/60Hz/1	110-126V



For more information or to place an order, contact your sales representative or authorized distributor.

Phone: 1-800-238-3600
Fax: 1-800-535-4235

www.cornelius.com