



INSTALLATION INSTRUCTIONS

ED300 “K” STYLE LID FOR KITS P/N 08025 AND P/N 08028

These “K” style kits apply to the following Ice Makers:

Table 1. Applicable Ice Maker Models

Ice Maker	Width
Cornelius “I” Series 330/530/630/830/1030/1230	30 inch
Cornelius “I” Series 322/522	22 inch
Cornelius AC/WC322	22 inch
Crystal Tips 600C/800C	32 inch
Crystal Tips 200C/300C/400C	22 inch
Ice-O-Matic GC650/750/1200	30 inch
Ice-O-Matic GC300/550	22 inch
Ice-O-Matic ICE320/520	22 inch
Scotsman SLC 300/400	22 inch
Scotsman CME306/456	22 inch

Table 2. Loose Shipped Parts

Item No.	Part No.	Name	Qty.
1	15210	Lid Assembly	1
2	22127	Icemaker Mounting Bracket	2
3	50904	RTV. 3Oz Tube	1
4	52946	Manual Ice Fill Cover - Black (08027)	1
	52964	Manual Ice Fill Cover - Gray (08030)	
5	91957	Label, “Disconnect Power Before Cleaning”	1
6	620042919	ED300 Ice Baffle	1
7	620701601	#10 x 1/2” LG. Sheetmetal Screw	8
8	620701902	#8-32 Nylon Acorn Nut	4
9	620701901	Sealing Washer	4
10	621701903	#8 Nylon Washer	4
11	92231	Installation Instructions	1
12	630000408	Bin Thermostat Kit Cornelius Icemakers	1

⚠ WARNING:

Disconnect power to the unit before installing the adaptor following all lockout/tag out procedures established by the user. Verify that all the power is off to the unit before performing any work.

Failure to comply could result in serious injury, death or damage to the equipment.

⚠ WARNING:

All of the attachment screws and plates must be installed as directed in this manual.

Failure to comply could result in serious injury, death or damage to the equipment.

⚠ WARNING:

All ice baffle plates and bin stats, if included or recommended in this kit, must be installed as directed in this manual or the equipment manufacturer’s instructions.

Failure to comply could result in serious injury, death or damage to the equipment.

 **WARNING:**

The dispenser must be secured with 3/8 X16 bolts (6) to the counter before installing the ice maker adapter kit. Refer to the installation manual and Fig 2 for the counter mounting template.

NOTE: Adjust the automatic agitation timer located in the dispenser's electrical control box to 5 seconds on, 20 minutes off. Access to the timer is provided by removing the merchandiser/upper front panel.

1. Remove the (2) screws from each side of the dispenser cabinet, and the plastic hopper covers (2) that were shipped with the unit.
2. Place the "K" style lid on the unit and use the (4) screws that were removed to fasten the lid in place.
3. Install the ice baffle on the lid assembly as shown in Figure 2.

IMPORTANT: The baffle prevents ice from over-filling the manual fill area during agitation/dispensing with a full storage bin and forcing the manual fill cover off.

4. Seal the icemaker to the top of the dispenser after determining the correct location for the ice maker (see Figure 1).
 - A. Run beads of RTV around the opening in the lid and inside of the perimeter of the ice maker outline so that the ice maker will set on the RTV.
 - B. Set the ice maker onto the lid and position it as required.
 - C. Wipe away the excess RTV.
5. Drill .147 diameter holes into the ice maker cabinet and the dispenser lid using the icemaker mounting brackets as templates. **USE CAUTION SO AS NOT TO DRILL INTO ANY ICEMAKER COMPONENTS (CONDENSER, TUBING, ETC.).** Secure the brackets using the #10 sheetmetal screws provided.
6. Follow the icemaker manufacturer's instructions to complete the installation of the ice maker including the bin thermostat if so equipped or required.

NOTE: For Cornelius Ice Makers follow the instructions in the 630000408 kit to install the bin thermostat.

IMPORTANT: Do not use the spacers provided for mounting the bin thermostat capillary tube to the icemaker base.

 **CAUTION:**

The bin thermostat location must not interfere with agitator rotation.

7. Locate the cleaning caution label (item 5) on the manual ice fill cover (item 4) as shown in Figure 1. Place the manual fill cover in position over the flange on the lid assembly and the front access hopper opening.

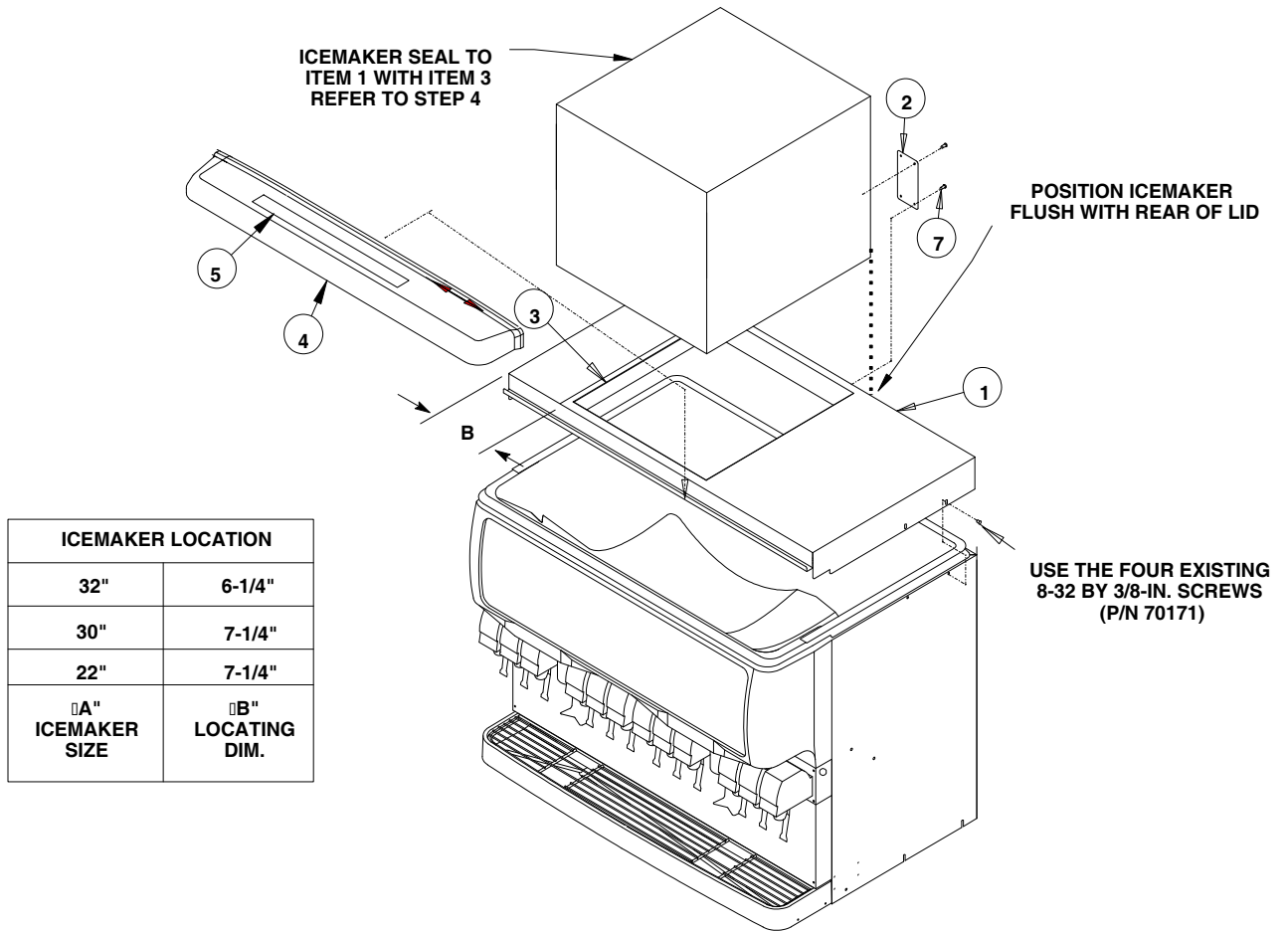

Figure 1. Dispenser

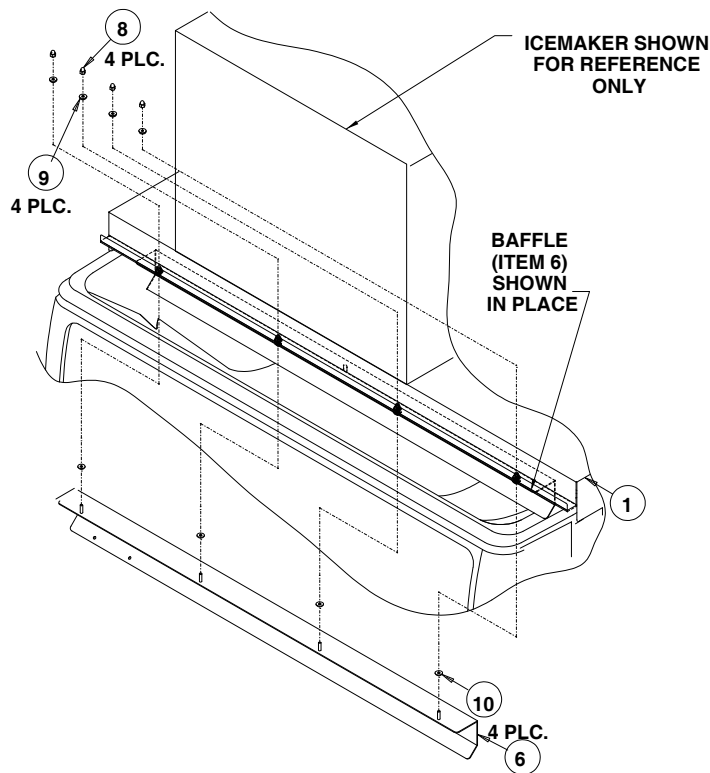
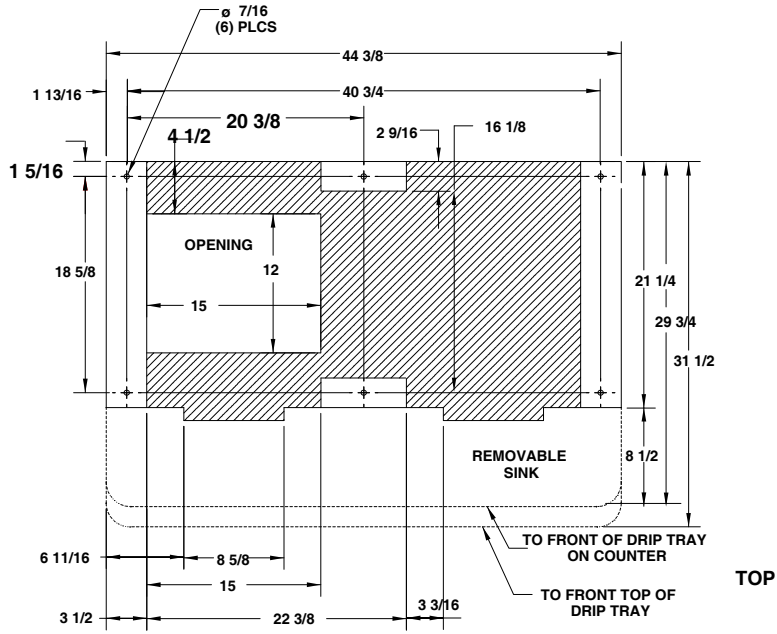

Figure 2. ED300 Baffle Kit



RECOMMENDED COUNTER OPENING SIZE 12" X 15"
FOR UTILITIES AND BEVERAGE TUBING.

Figure 3. Mounting Template