



INSTALLATION INSTRUCTIONS

ED300 ICE MAKER ADAPTER LID FOR KITS P/N 08026 AND P/N 08029

These kits apply to the following ice makers:

Table 1. Applicable Ice Maker Models

Ice Maker	Size
Scotsman CM250/500/650, CME256/506/656	30 inch
SerVend C2/4/7/9	30 inch
Manitowoc B450/600/800/1000	30 inch
Manitowoc Q320/420	22 inch
Manitowoc Q280/450/600/800/1000	30 inch
Manitowoc QQ600/800/1000C	30 inch
Ice-O-Matic C106	30 inch
Ice-O-Matic EC200/300/400/500/600/800	30 inch
Ice-O-Matic ICE250/400/500/600/800/1000	30 inch

Table 2. Loose Shipped Parts

Item No.	Part No.	Name	Qty.
1	15209	Adapter Lid	1
2	22127	Ice Maker Mounting Bracket	2
3	50904	RTV, 3 oz. Tube	1
4	52946	Manual Fill Cover (Black – 08026)	1
	52964	Manual Fill cover (Gray – 08029)	
5	91957	Label, “Disconnect Power Before Cleaning”	1
6	620042919	ED300 Ice Baffle	1
7	70226	#10 x 3/4-inch Long Sheet metal Screw	12
8	620701902	#8-32 Nylon Acorn Nut	4
9	620701901	Sealing Washer	4
10	611701903	#8 Nylon Washer	4
11	15192	Lid Opening Cover (For 22-inch Wide Ice Makers)	2

⚠ WARNING:

Disconnect power to the unit before installing the adaptor following all lockout/tag out procedures established by the user. Verify that all the power is off to the unit before performing any work.

Failure to comply could result in serious injury, death or damage to the equipment.

⚠ WARNING:

All of the attachment screws and plates must be installed as directed in this manual.

Failure to comply could result in serious injury, death or damage to the equipment.

⚠ WARNING:

All ice baffle plates and bin stats, if included or recommended in this kit, must be installed as directed in this manual or the equipment manufacturer’s instructions.

Failure to comply could result in serious injury, death or damage to the equipment.

 **WARNING:**

The dispenser must be secured with 3/8 X16 bolts (6) to the counter before installing the ice maker adapter kit. Refer to the installation manual and Figure 2 for the counter mounting template.

NOTE: Adjust the automatic agitation timer located in the dispenser's electrical control box to 5 seconds on, 20 minutes off. Access to the timer is provided by removing the merchandiser/upper front panel.

1. Remove the two (2) screws from each side of the dispenser cabinet and the plastic hopper covers (2) that were shipped with the unit.
2. Place the Adapter lid on the unit and use the four (4) screws that were removed to fasten the lid in place.
3. Install the ice baffle on the lid assembly as shown in Figure 2.

IMPORTANT: The baffle prevents ice from over-filling the manual fill area during agitation/dispensing with a full storage bin and forcing the manual fill cover off.

4. Seal the ice maker to the top of the dispenser after determining the correct location for the ice maker (see Figure 1).
 - A. Run beads of RTV around the opening in the lid and inside of the perimeter of the ice maker outline so that the ice maker will set on the RTV.
 - B. Set the ice maker onto the lid and position it as required.
 - C. Wipe away the excess RTV.
5. Drill .136 diameter holes into the ice maker cabinet and the dispenser lid using the ice maker mounting brackets as templates. **USE CAUTION SO AS NOT TO DRILL INTO ANY ICE MAKER COMPONENTS (CONDENSER, TUBING, ETC.).** Secure the brackets using the #10 sheet metal screws provided.
6. Follow the ice maker manufacturers instruction to complete the installation of the ice maker including the bin thermostat if so equipped or required.

 **CAUTION:**

The bin thermostat location must not interfere with agitator rotation.

7. For 22-inch wide Ice makers, locate the lid opening covers (2) item 11 as shown in Figure 1. Secure the covers to the adapter lid by drilling .136 diameter holes into the lid. Use the covers as templates to locate the mounting holes. Secure the covers with the # 10 sheet metal screws.
8. Locate the cleaning caution label (item 5) on the manual ice fill cover (item 4) as shown in Figure 1. Place the manual fill cover in position over the flange on the lid assembly and the front access hopper opening.

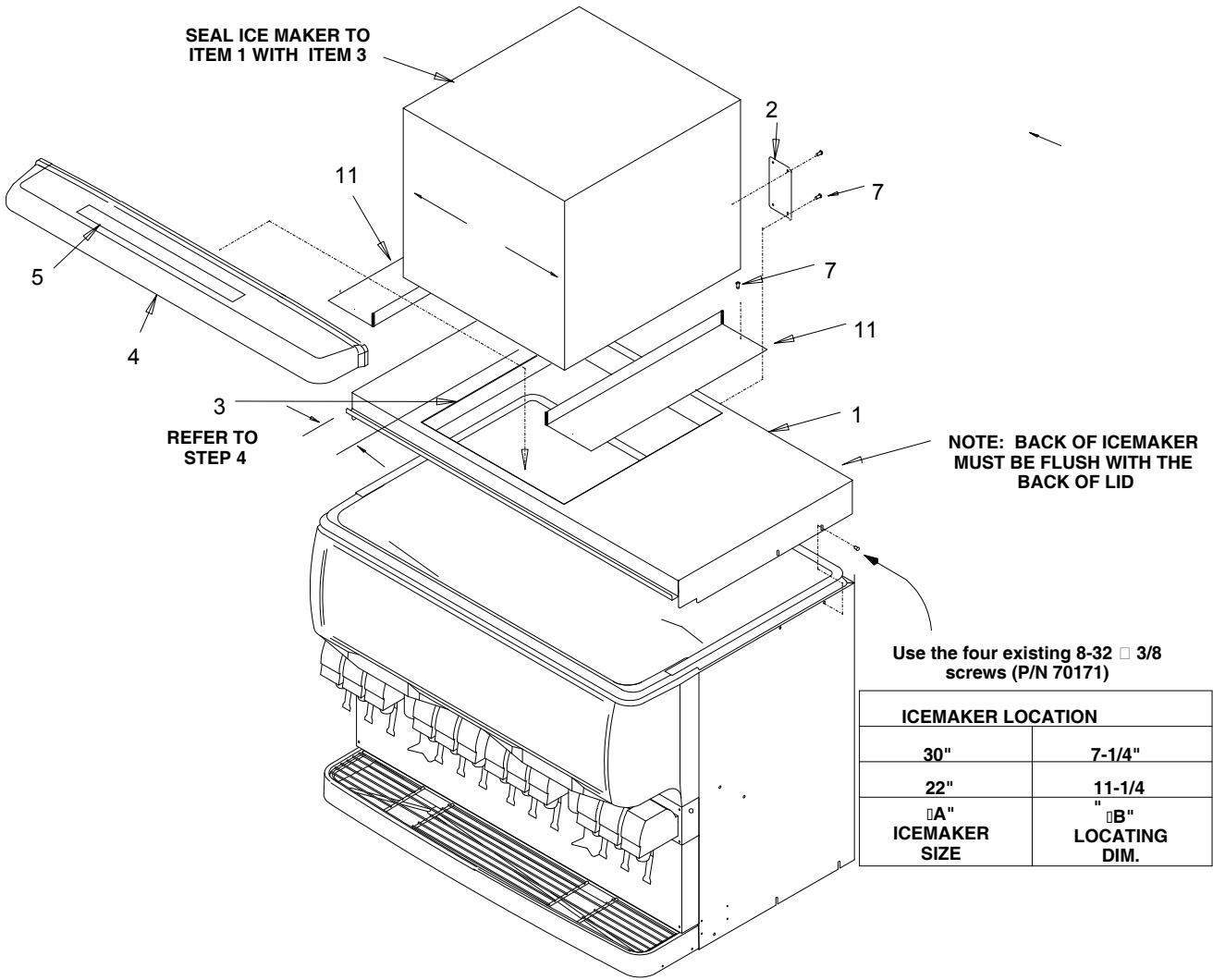

Figure 1. Dispenser

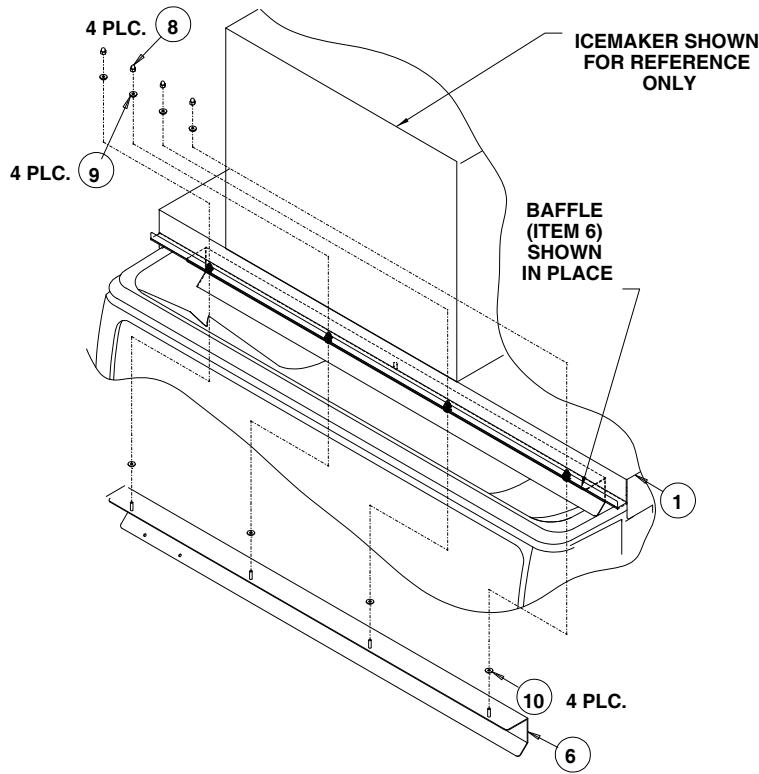

Figure 2. ED300 Baffle Kit

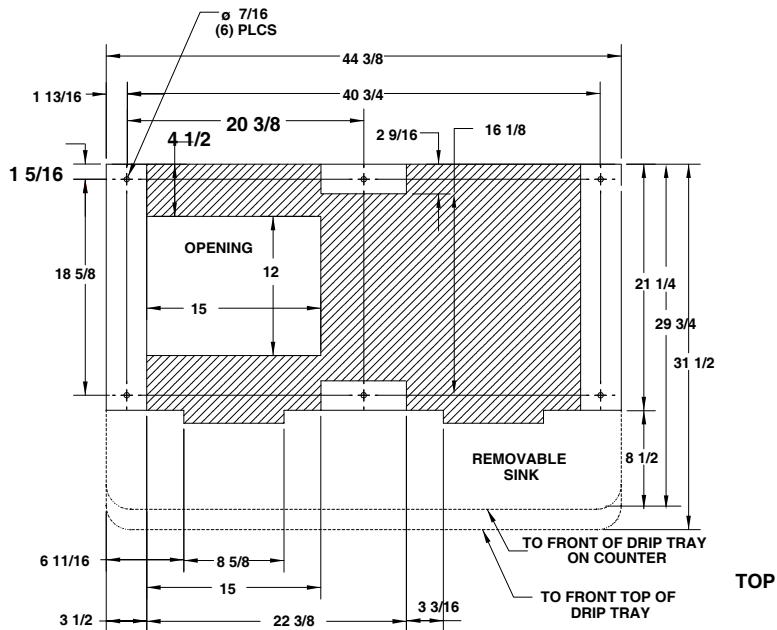

Figure 3. Mounting Template