

INSTALLATION INSTRUCTIONS

FLAVORFUSION ICEMAKER ADAPTOR KIT FOR P/N 629088668, 629088669, 629088670, AND 629088671

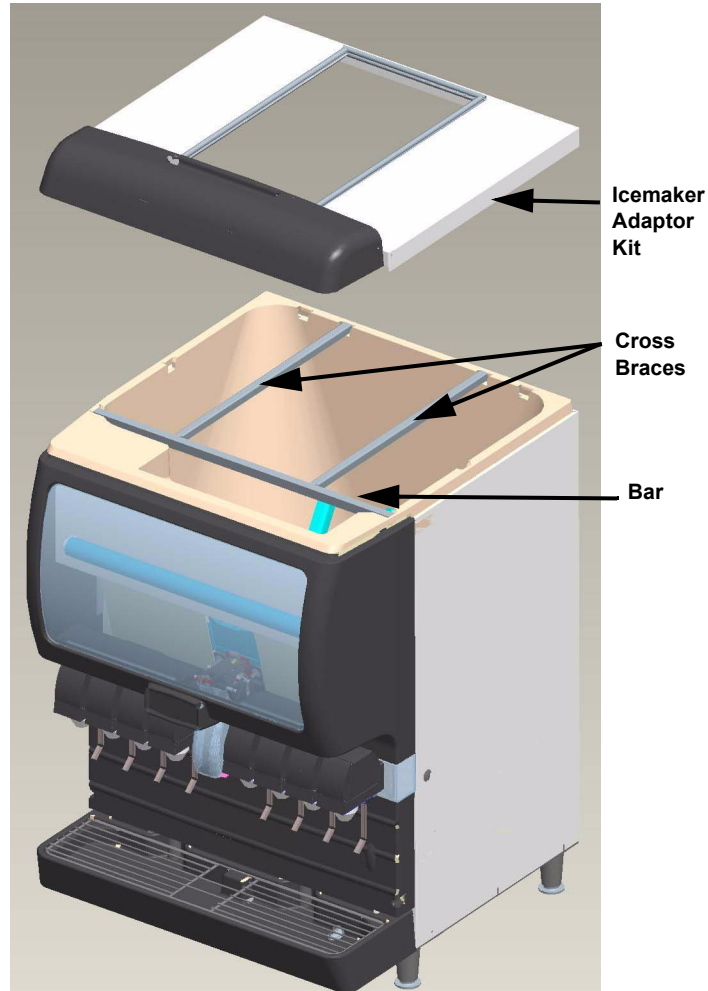

FIGURE 1

⚠ WARNING:

Disconnect power to the unit before installing adaptor following all lock out / tag out procedures established by the user. Verify all of the power is off to the unit before performing any work. Failure to comply could result in serious injury, death or damage to the equipment.

⚠ WARNING:

All of the attachment screws and plates must be installed as directed in this manual. Failure to comply could result in serious Injury, Death or Damage to the equipment.

1. Place ice slide into ice drop opening in bin (see Figure 2).

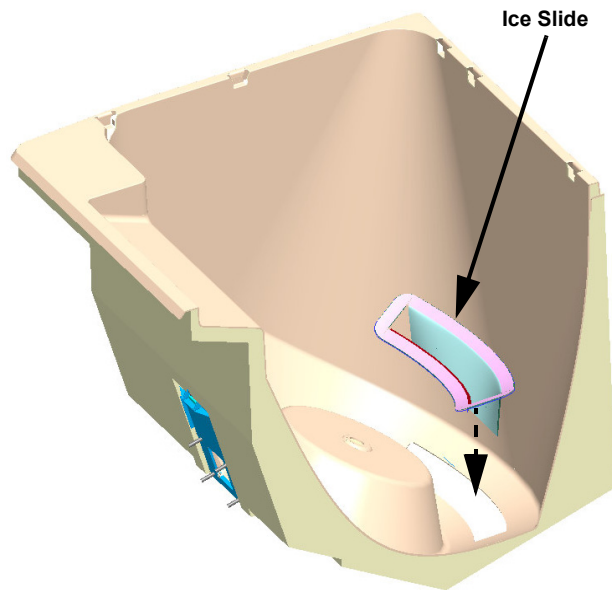

FIGURE 2 Ice Slide Assembly

2. Place Icemaker rail support into pockets in the ice bin as shown in Figure 3

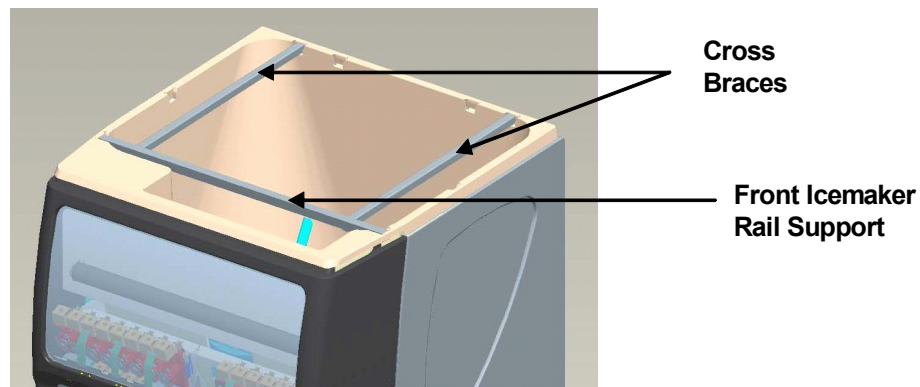

FIGURE 3

3. Place bar into first set of pockets inside the ice bin.
4. Hook cross braces over top of bar and place into inner pockets inside the ice bin (at back end).
5. Place Icemaker Adaptor Kit on top of unit.
6. Place icemaker on top of kit. DO NOT slide icemaker into position on the lid.
7. Apply continuous bead of NSF international (NSF) listed silastic sealant (Dow 732 or equivalent), supplied in kit, to seal the icemaker to the top of the adapter kit. All excess sealant must be wiped away immediately.

8. The next steps discuss loading and securing the icemaker onto the kit. Please read all the following steps to determine which mounting method should be utilized. Equally important is to determine if there is sufficient access in the area of the mounting brackets after the dispenser is lifted onto the counter. Access should be carefully considered before installation continues because sufficient room is required for drilling holes, installing screws, etc.

Two options are supplied with this kit for securing the icemaker to the kit. (See Figure 4)

Option 1: Includes two flat brackets. This method may be used if there is sufficient access to the back of the dispenser in the areas of the mounting brackets.

Option 2: Includes two angle brackets. This method may be used if there is not sufficient access to the back of the dispenser in the areas of the mounting brackets. Pre-drilling holes should be considered when using this option.

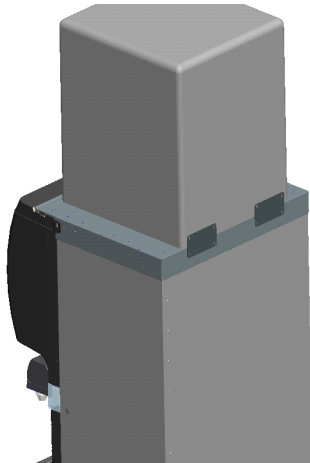

MOUNTING OPTION 1
(FLAT BRACKETS)

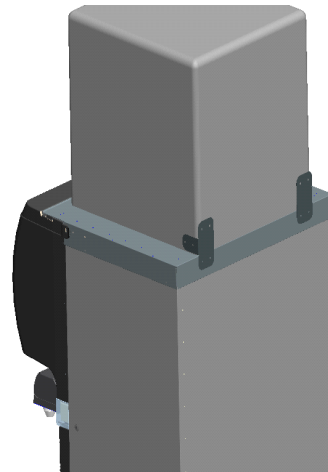

MOUNTING OPTION 2
(ANGLE BRACKETS)

FIGURE 4

9. The next step is to secure the icemaker to the kit. Depending on the mounting method chosen, use the appropriate brackets (supplied) as templates to drill four 9/64" (.140" Dia.) holes into the back side of the adapter kit. Drill four holes of the same diameter into the icemaker (Figure 4). Ensure the location of the brackets will not damage the kit or the icemaker prior to drilling any holes. **USE EXTREME CAUTION NOT TO DRILL INTO ANY OTHER COMPONENTS.** Drill depths should not go further than the thickness of the material being drilled (just enough to go through). Secure the two brackets using the screws provided.

For optimal performance, do not fill ice bin more than 2/3 capacity (maximum fill is 4" below top of bin).