

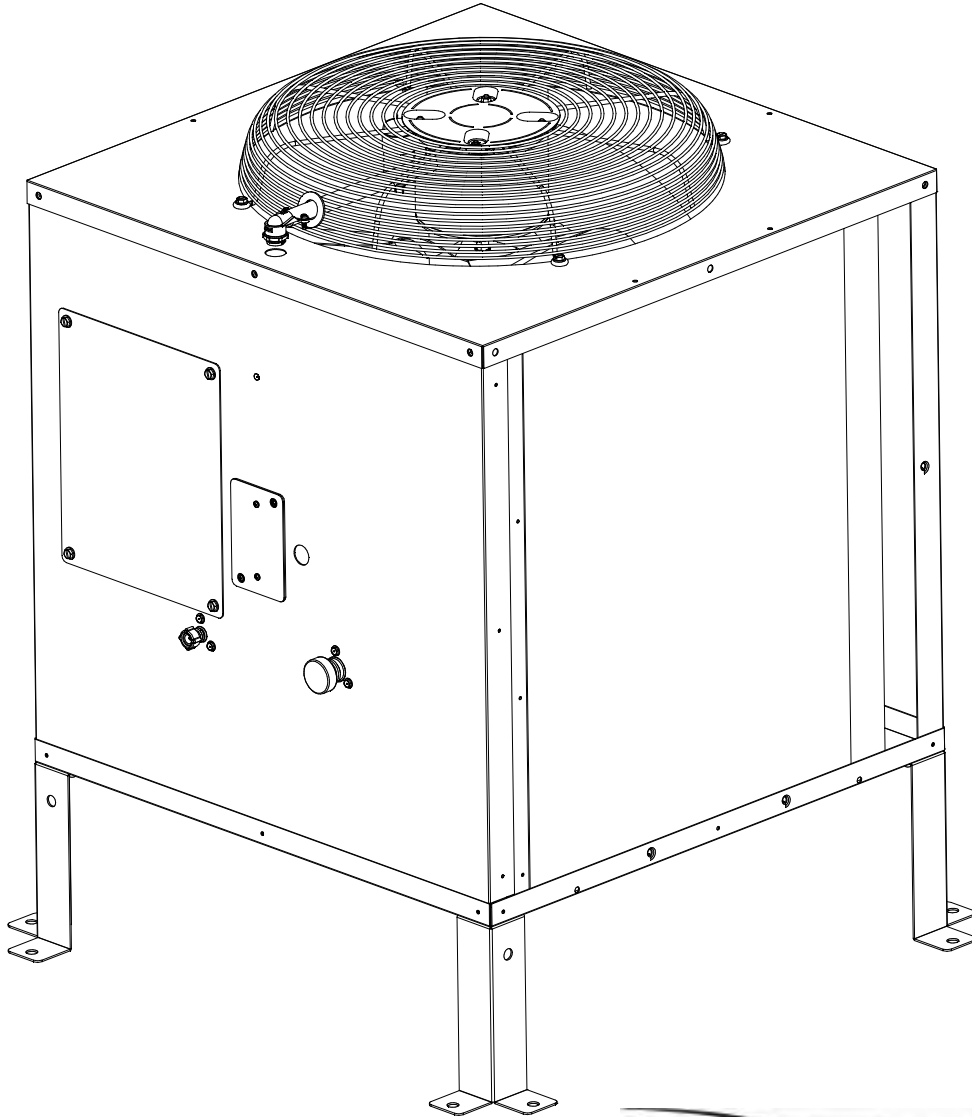

Nordic Remote Condenser

Model: RCN1001, RCN1061, RCN2061, RCN3061

Installation Manual



Publication Number: RCN1061INS

Revision Date: August 22, 2017

Revision: A

Visit the Cornelius web site at ice.cornelius.com for all your Literature needs.

How To Use This Manual

Cornelius provides this manual as an aid to the service technician in installation and maintenance of remote condensers. Do not attempt to perform installation, start-up or maintenance unless you have read and fully understand this manual.

If, at any time, you encounter conditions that are not addressed in this manual, call or E-mail the Cornelius Service Department:

E-Mail: Tech.service@cornelius.com

Telephone Numbers

800-238-3600 All Departments

Any Service communication must include:

- Model Number
- Serial Number
- A detailed explanation of the problem

Keep this manual for future reference.

Cornelius icemakers and dispensers are not approved for outdoor installation.

WARNING: Always disconnect electrical power whenever maintenance or repairs are performed on the remote condenser.

CAUTION: Always wear protective eyewear whenever maintenance or repairs are performed on the ice machine and related equipment.

Introduction	Page i
Table of Contents	Page ii
Freight Claim Procedure	Page iii
General Information	Page 1
Remote Refrigeration System	Page 7
Component Description	Page 8
Installation Guidelines	Page 9
Condenser Leg Installation	Page 10
Refrigeration Tubing Routing	Page 11
Coupling Instructions	Page 13

Freight Claims Important!**Inspect Promptly**

This merchandise has been carefully inspected and packed in accordance with the carrier's packing specifications. Responsibility for safe delivery has been assumed by the carrier. If loss or damage occurs, you as the consignee must file a claim with the carrier and hold the container for carrier's inspection.

Visible Loss or Damage

Any external evidence of loss or damage must be fully described and noted on your freight bill or express receipt and signed by the carrier's agent. The claim should be filed on a form available from the carrier.

Concealed Loss or Damage

If loss or damage does not appear until merchandise has been unpacked, make a written request for inspection by the carrier within 5 days of the delivery date. Then file a claim on a form from the carrier.

File Claim Without Delay

Do Not Return Damaged Merchandise to Cornelius.

Condenser Dimensions (Inches)

<u>Model</u>	<u>Length</u>	<u>Width</u>	<u>Height</u>	<u>Grill Kit Field Installed</u>
RCN1001	30.85	30.85	37.01	620060081
RCN1061	30.85	30.85	37.01	620060081
RCN2061	30.85	30.85	41.79	620060082
RCN3061	30.85	30.85	37.10	620060083

The RCN models **DO NOT** include side grills, they can be ordered as a Field Install Kit, See Specific Model Number for Kit Part Number

RCN Condenser

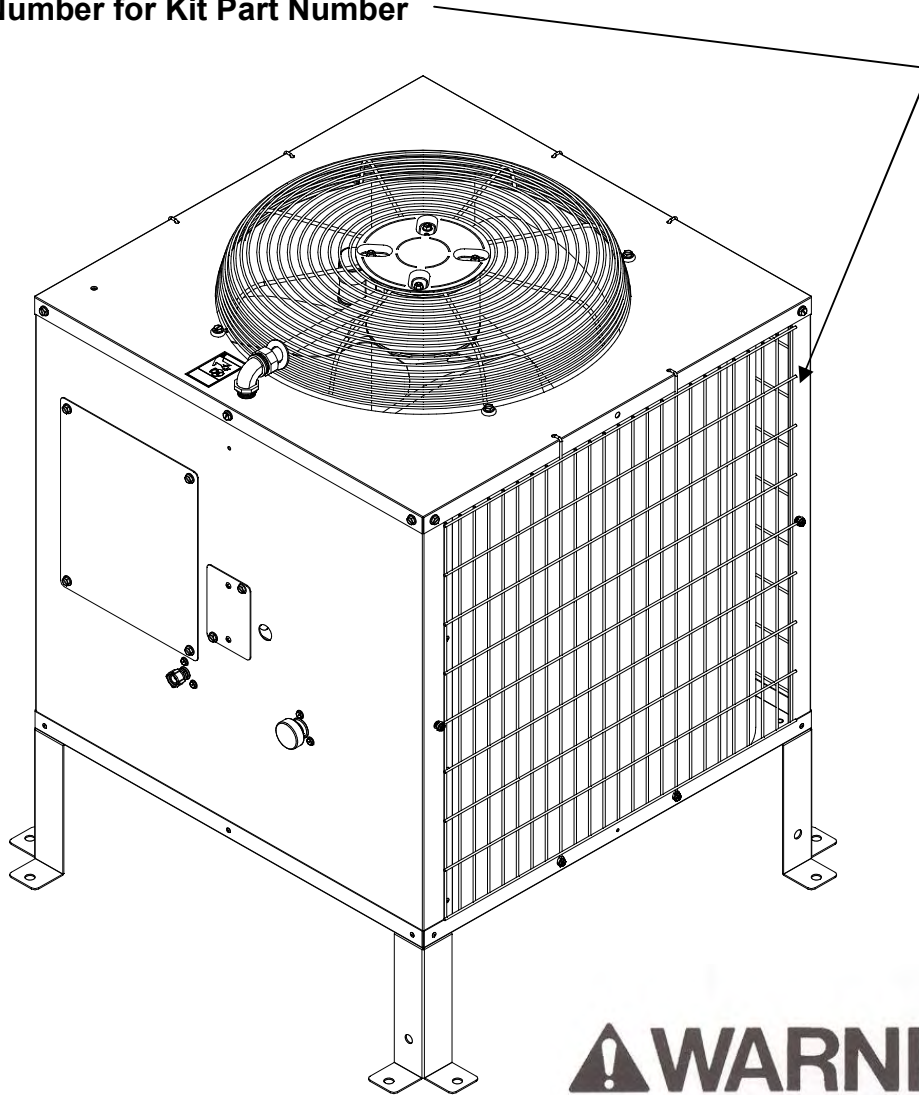

Note the warning symbol where it appears in this manual. It is an alert for important safety information on a hazard that might cause serious injury. Keep this manual for future reference.

Condenser Dimensions (Inches) 30.85 x 30.85 x 37.01

Remote Condenser	Ice Machine Model
RCN1001	CCM0530R
RCN1061	CCM0630R, CNM0630R, CCM0830R, CNM0830R

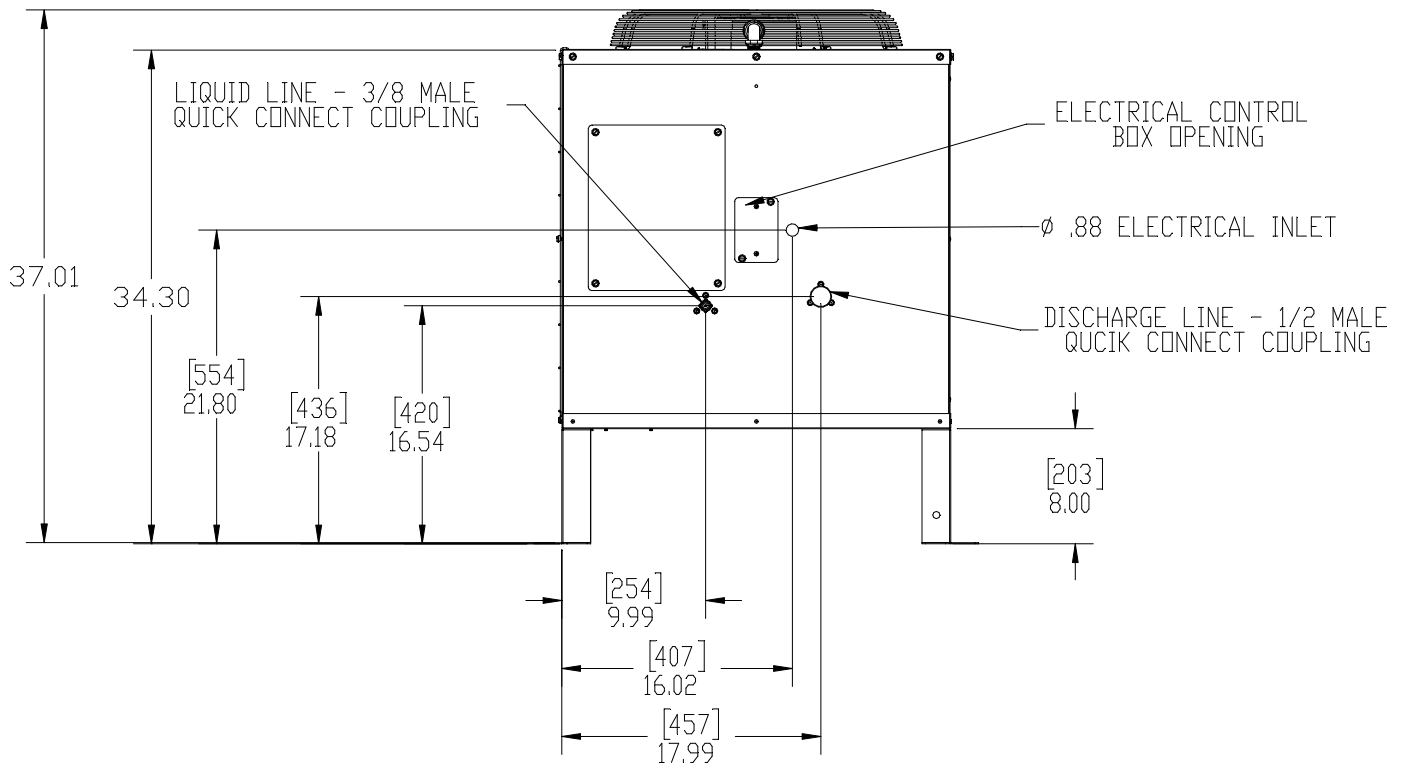
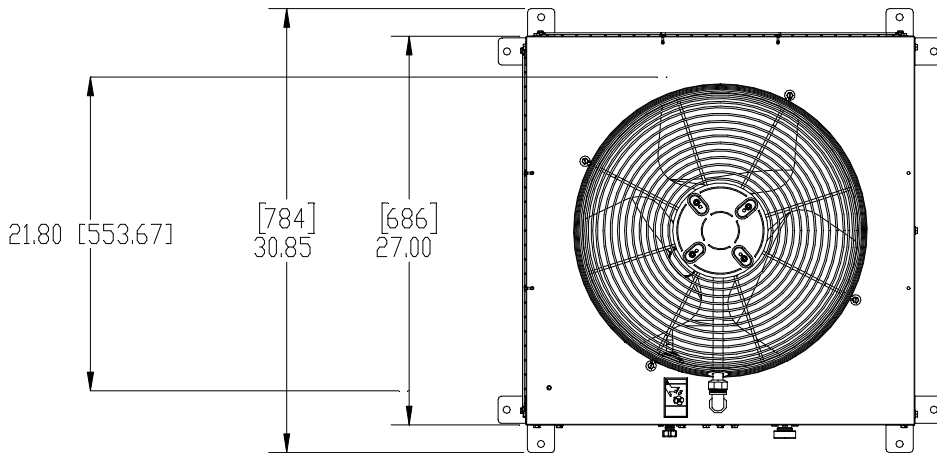

Condenser Dimensions (Inches) 30.85 X 30.85 X X41.79

Remote Condenser Ice Machine Model

RCN2061

**CCM1030R, CNM1030R, CCM1530R, CCM1448R, CCM1848R
CNM1530R**

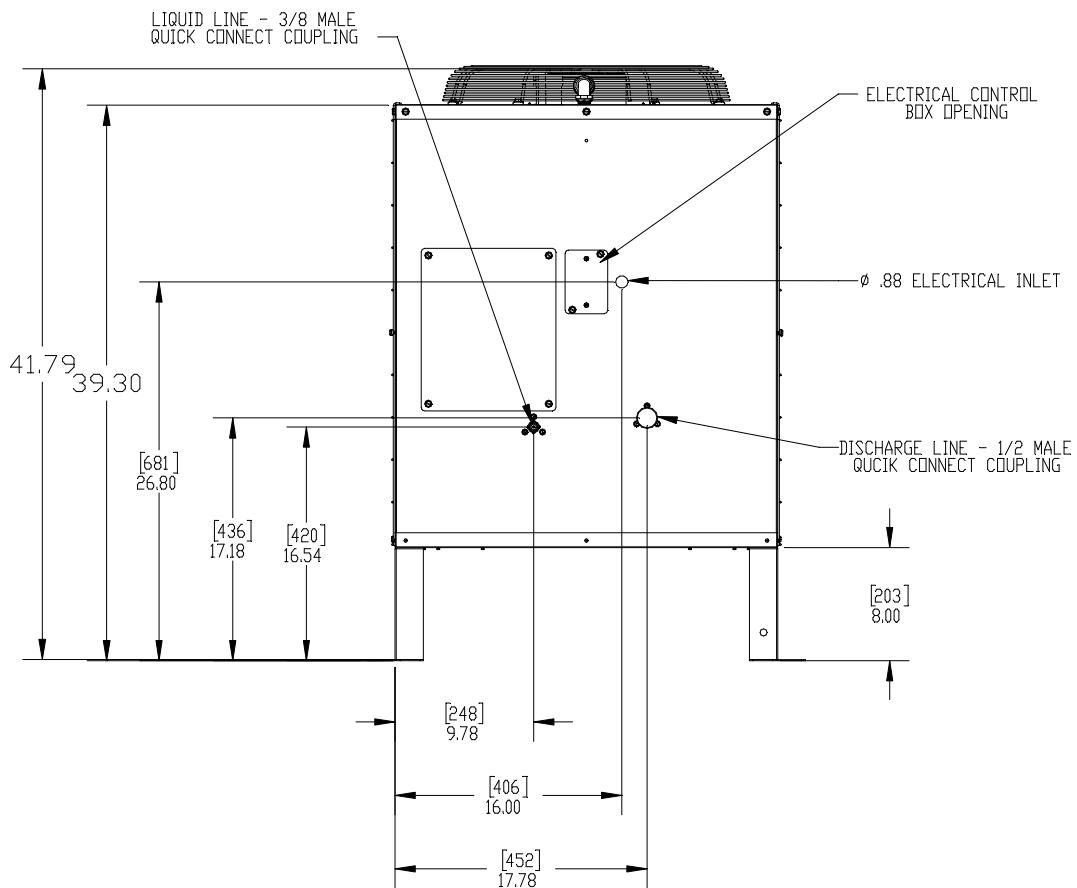
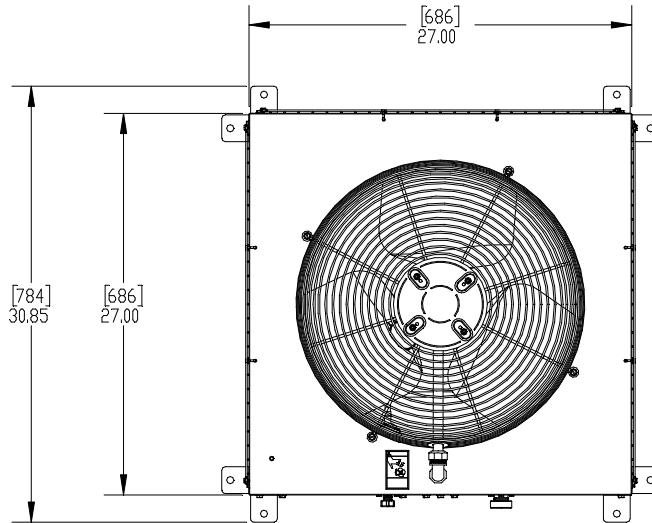

Condenser Dimensions (Inches) 30.85 X 30.85 X 37.10

<u>Remote Condenser</u>	<u>Ice Machine Model</u>
RCN3061	CCM2148R
	CNM2148R

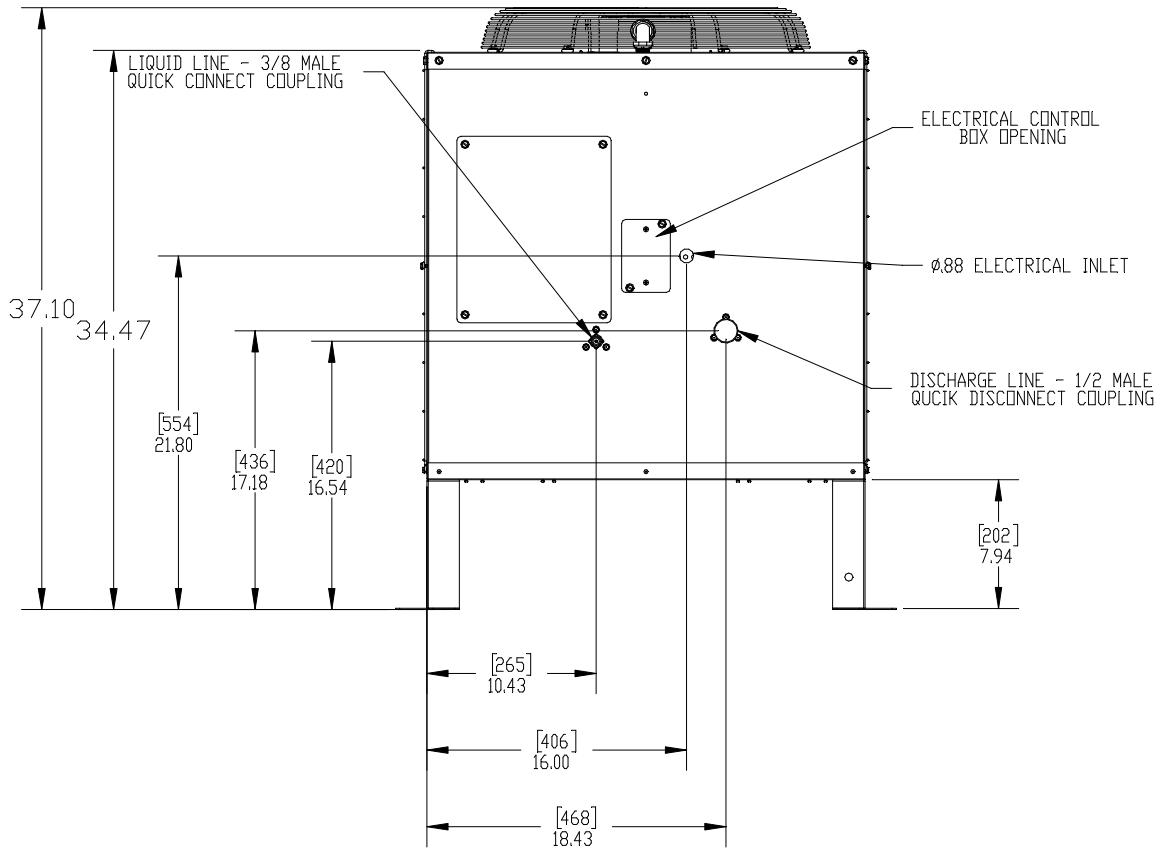
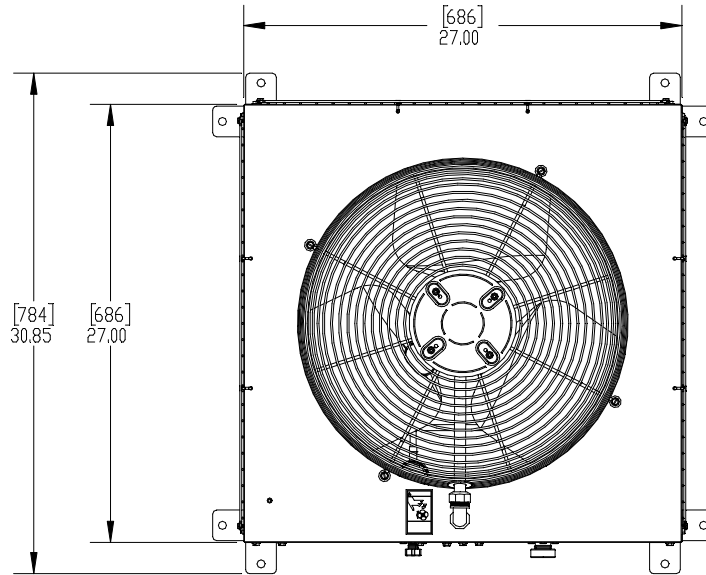

Introduction

Cornelius Remote Condenser Systems are comprised of three components. The pre-charged remote condenser, the pre-charged ice maker and the pre-charged line set. The pre-charged line sets are available in 25, 40, or 75 foot line set lengths. The 75 foot line set will require adding an additional 28 ounces of refrigerant to the system.

Normal installation of the ice maker should be followed. Reference the installation instructions included with the ice maker.

In any installation, the pre-charged line sets, consisting of a liquid line (3/8" dia.) and a discharge line (1/2" dia.) are used as a one time initial charge type installation.

Once the sealed couplings are connected and the internal seal is broken, the lines cannot be disconnected without losing the refrigerant charge. They are, however, reusable and when the couplers are removed and reconnected, the complete refrigeration system must be evacuated and re-charged with the proper amount of refrigerant. Reference the ice maker data plate or ice maker service manual for proper refrigerant charge.

General Description

The remote condenser should not be used in areas where sufficient airflow is not available in the area the ice maker is being installed or the heat being rejected by the condenser coil will be undesirable.

The condenser coil should not be exposed to temperatures below -20°F (-29°C) or above 120°F (49°C).

The remote condenser functions as a normal refrigeration system until the temperature at the condenser coil drops below 70°F. At this time the mixing valve will begin to bypass enough hot gas from the discharge line directly into the receiver to keep the liquid line feeding the expansion valve at a steady pressure. The amount of gas bypassed will depend on the temperature at the condenser coil (the colder the temperature at the condenser coil, the more gas will bypass and the tubing between the mixing valve and receiver will become warmer).

Condenser Location

When choosing a location for the remote condenser, reference the following guidelines:

1. Choose a location that is protected from extremes of dirt, dust, rain, sun and prevailing winds.
2. Vertical air discharge mounting of the condenser is required.
3. Condenser should be mounted higher than the ice machine.
4. Condenser must be level.
5. Condenser should not be exposed to temperatures below -20°F or above 120°F.
6. Installation must meet all local and national building, plumbing and electrical codes.

Condenser shown with field installed side grills.

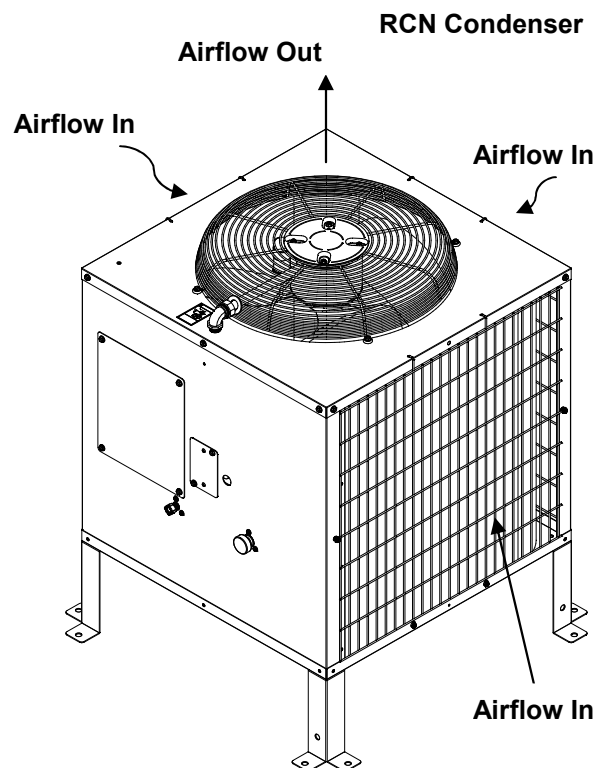

The **RCN** remote condensers incorporate the mixing valve in the condenser. This configuration allows up to a 100 foot calculated remote line set run. Reference the diagram below to calculate the maximum 100 foot line set run.

Maximum Rise is 35 feet.
Maximum Drop is 15 feet.
Maximum equivalent run is 100 feet.

Formula for figuring maximum equivalent run is as follows:

Rise x 1.7 + Drop x 6.6 + horizontal run = equivalent run.

Examples: 35 ft. rise x 1.7 + 40 ft. horizontal = 99.5 equivalent feet line run

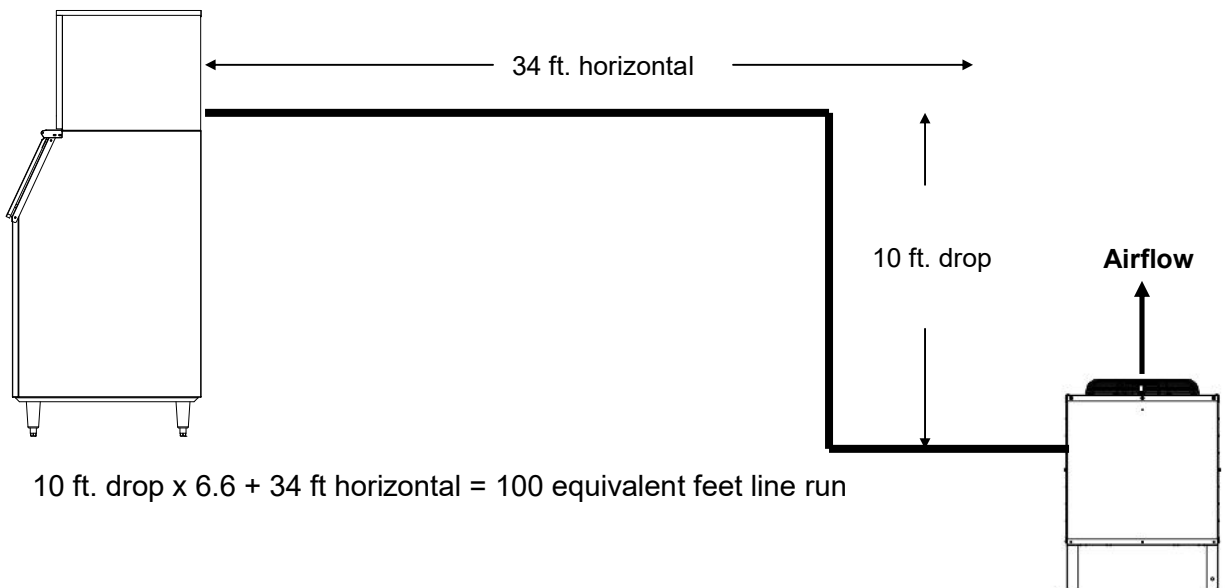
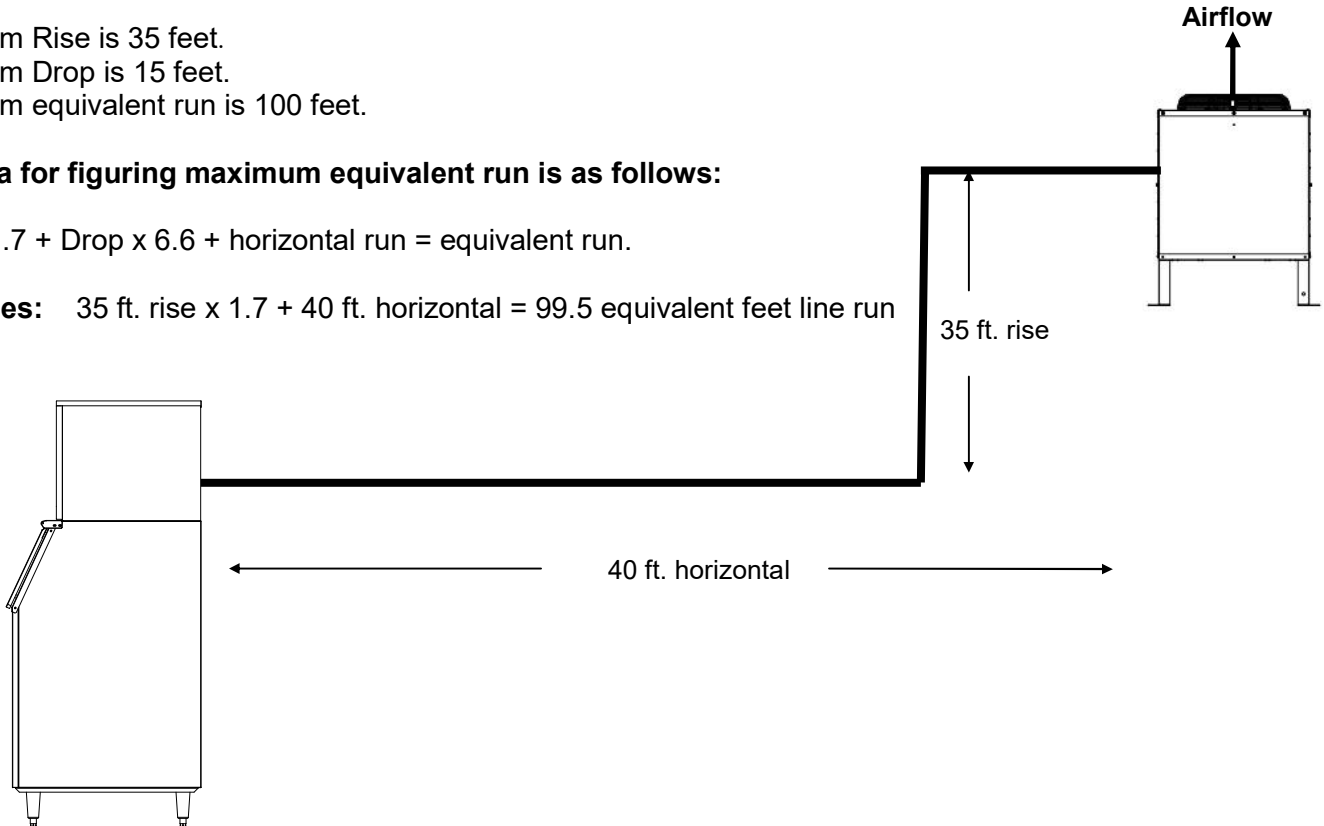

10 ft. drop x 6.6 + 34 ft horizontal = 100 equivalent feet line run

Remote Condenser

Remote Refrigeration System

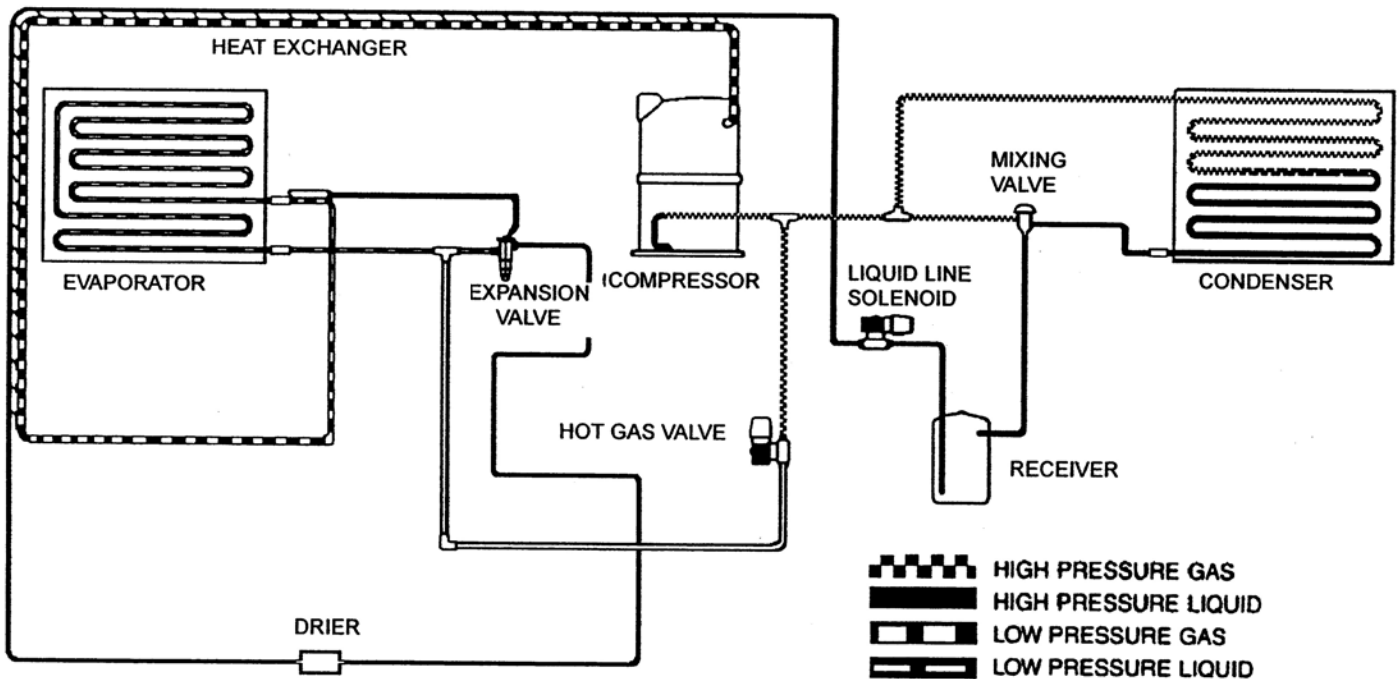

The Remote Refrigeration System is shown in the above diagram. During the freezing cycle, high temperature and high pressure liquid refrigerant is directed from the condenser through a mixing valve, receiver, liquid line solenoid heat exchanger and a filter drier. The expansion valve meters refrigerant to the coils on the back of the evaporator.

In low ambient conditions (below 70°F air temperature at the condenser) the mixing valve opens to mix discharge gas with liquid returning from the condenser, in the receiver, to maintain discharge and liquid line pressures.

The low temperature and pressure refrigerant leaving the evaporator is directed through the suction line heat exchanger and is returned to the compressor. There it is compressed to a high temperature and high pressure gas. It is then directed to a condenser to be converted again to a high temperature and high pressure liquid.

During the harvest cycle, the hot gas solenoid valve (normally closed during the freeze cycle), opens and directs the high temperature gas leaving the compressor into the evaporator. Once the evaporator has reached approximately 40°F, the harvest motor overcomes the capillary attraction of the ice and the evaporator releases the ice. At the end of the harvest cycle, the hot gas solenoid valve closes and another freeze cycle begins.

During the off cycle, the liquid line solenoid valve closes.

Mixing Valve (Headmaster, Low Ambient Control Valve)

This valve serves as the head pressure regulating valve. It contains a pre-determined charge of nitrogen in the valve bellows. When the temperature at the condenser is above 70°F (21°C), the refrigerant flow from the compressor is directed by the mixing valve through the condenser and into the receiver. When the temperature at the condenser drops below 70°F (21°C), the pressure in the bellows of the mixing valve becomes greater than the pressure of the liquid refrigerant coming from the condenser.

This change allows the valve to partially restrict the flow of refrigerant leaving the condenser and allows discharge gas to by-pass the condenser and flow directly into the receiver, mixing with the liquid refrigerant from the condenser. The amount of discharge gas that bypasses the condenser increases as the ambient temperature decreases.

This action of the mixing valve allows the discharge pressure to be maintained at approximately 217 psi during low ambient conditions. If the refrigerant system is undercharged and the ambient temperature is below 70°F (21°C), the mixing valve will not work properly. The mixing valve will allow too much refrigerant to bypass the condenser.

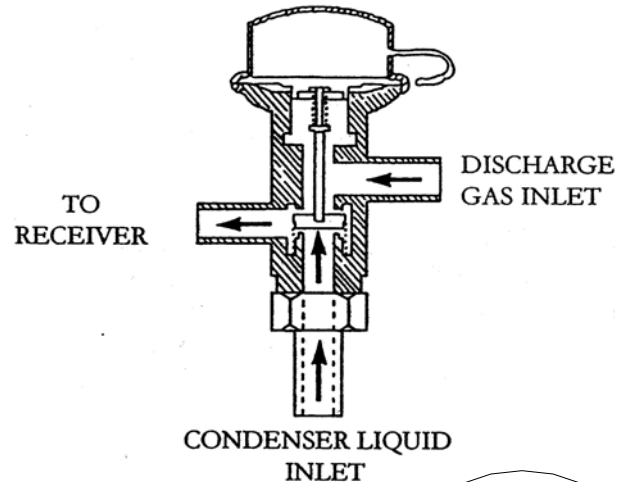

Receiver

The quantity of liquid refrigerant in the receiver will vary with the temperature at the condenser coil.

Liquid Line Solenoid and Pump Down Low Pressure Control

CCM Series

When the bin is full or the ON-OFF switch is turned to the OFF position, the liquid line solenoid valve closes and the system begins to pump down. When the low pressure reaches 10-20 psi, the pump down low pressure control opens and the contactor shuts the machine off.

As the ice is removed from the bin or the ON-OFF switch is turned to the ON position, the liquid line solenoid valve opens and the high side and low side pressures begin to equalize. When the low side pressure reaches 50-75 psi, the pump down low pressure control closes and the machine begins a freeze cycle.

When the machine is off for extended periods of time, it will pump down approximately once every hour. This is due to the equalization of pressures during the off cycle resetting the pump down low pressure control. It is a normal function of the refrigeration system.

CNM Series

When the bin is full or the machine is turned OFF, the machine will shut down 30 seconds after the pump down initiation.

The machine will pump down once every 2 hours, for 15 seconds during normal operation.

Condenser Fan Motor

The condenser fan motor is a single speed, permanent split capacitor motor and should be wired according to the wiring diagram. The motor is permanently lubricated for long service life.

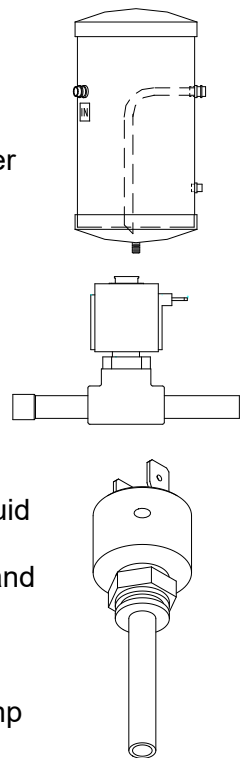

Electrical Connections

1. The icemaker and the remote condenser both require a solid earth ground that meets National, State and Local Codes.
2. The Remote Condenser is designed to be wired to the Cornelius ice maker.
3. Reference the ice machine and condenser date plate for current requirements to determine wire size for electrical hook up.
4. Make sure the supply voltage is the same as the rated voltage shown on the nameplate.
5. Reference wiring diagram below for proper connections.

INSTALLATION NOTICE:

THE RCN SERIES REMOTE CONDENSERS MAY ONLY BE USED WITH COMPATIBLE CORNELIUS ICE MAKERS

All Rack type Condenser systems must receive prior approval from Cornelius Engineering.

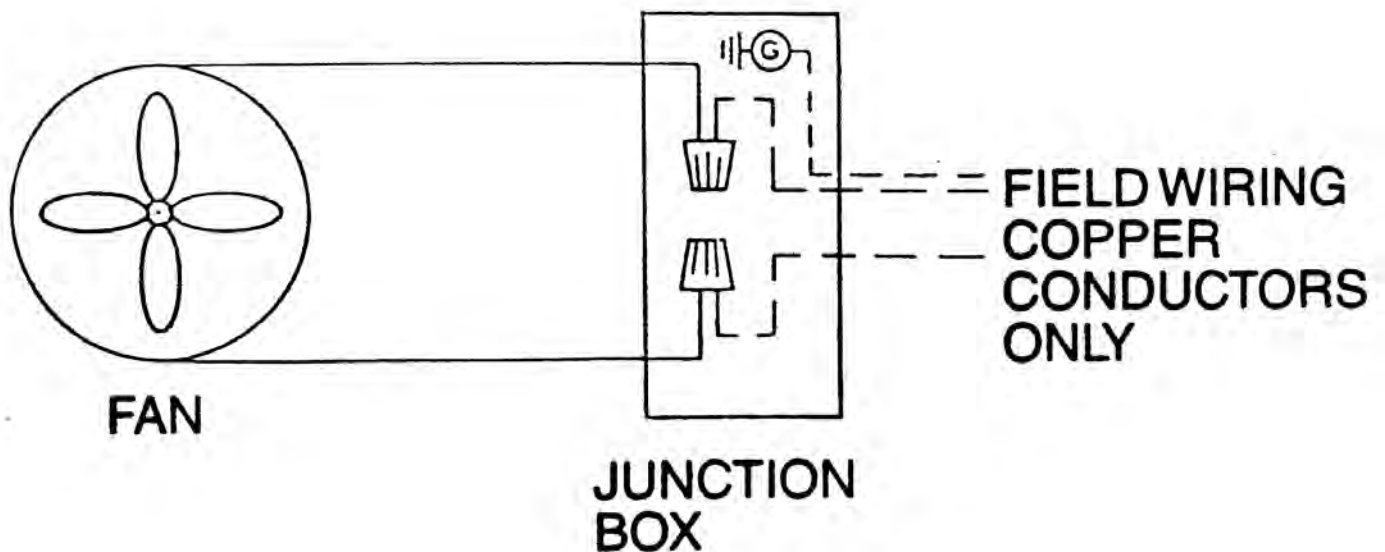

! WARNING

Electrical shock and/or injury from moving parts inside this machine can cause serious injury. Disconnect electrical supply voltage to the machine and condenser prior to performing any adjustments or repairs.

Support Leg Installation-RCN

1. After removal of the packaging and fasteners, lift the condenser assembly off of the skid.
2. Locate the legs attached to the condenser assembly on the top panel. Remove the fastener holding the legs to the top panel.
3. Assemble the legs to the condenser as shown below. Loosen the leg fastening nuts which are preinstalled on the base studs. **DO NOT remove the nuts.** Slide the legs in position and retighten the nuts.

Roof Attachment

1. Install and attach the remote condenser to the roof of the building using the methods and practices of construction that conform to the local building codes, including having a roofing contractor secure the remote condenser to the roof.
2. Have an electrician connect the remote condenser fan motor to the ice machine using the junction box on the rear of the ice machine. **Condenser shown with field installed side grills.**

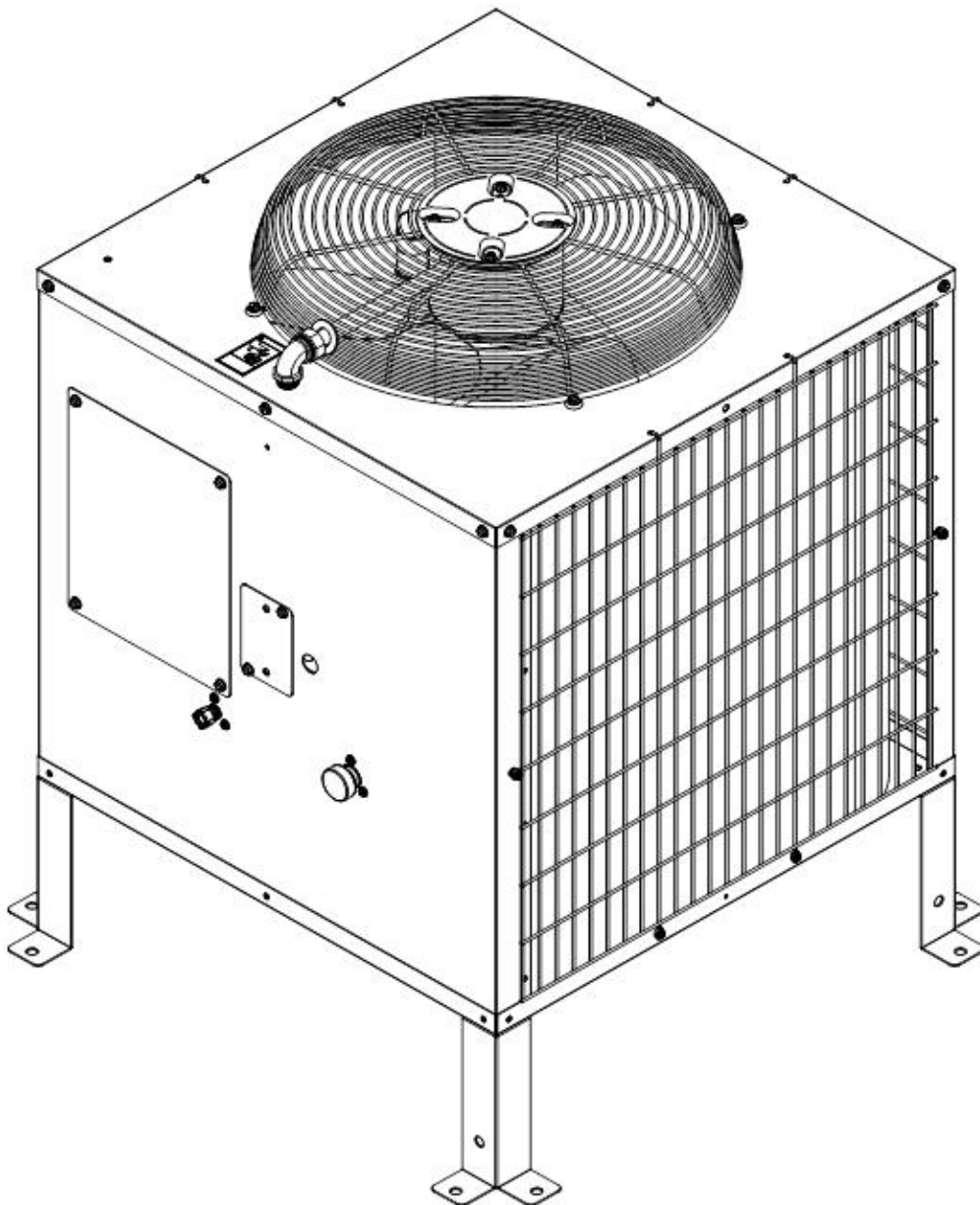

Proper Tubing Routing

When installing the discharge and liquid lines from the remote condenser to the icemaker, please use the following guidelines:

1. The remote condenser (#2) should always be installed above the icemaker (#4) as shown with a vertical air flow.
2. All excess tubing (#1) should be routed inside the building and coiled in a vertical spiral as shown (3#), to prevent oil trapping in the lines. Any tubing run outside should be insulated to protect it from surrounding ambient conditions. Tubing should follow straight line routing whenever possible. The lowest spot in the tubing run should be the connection at the rear of the icemaker.

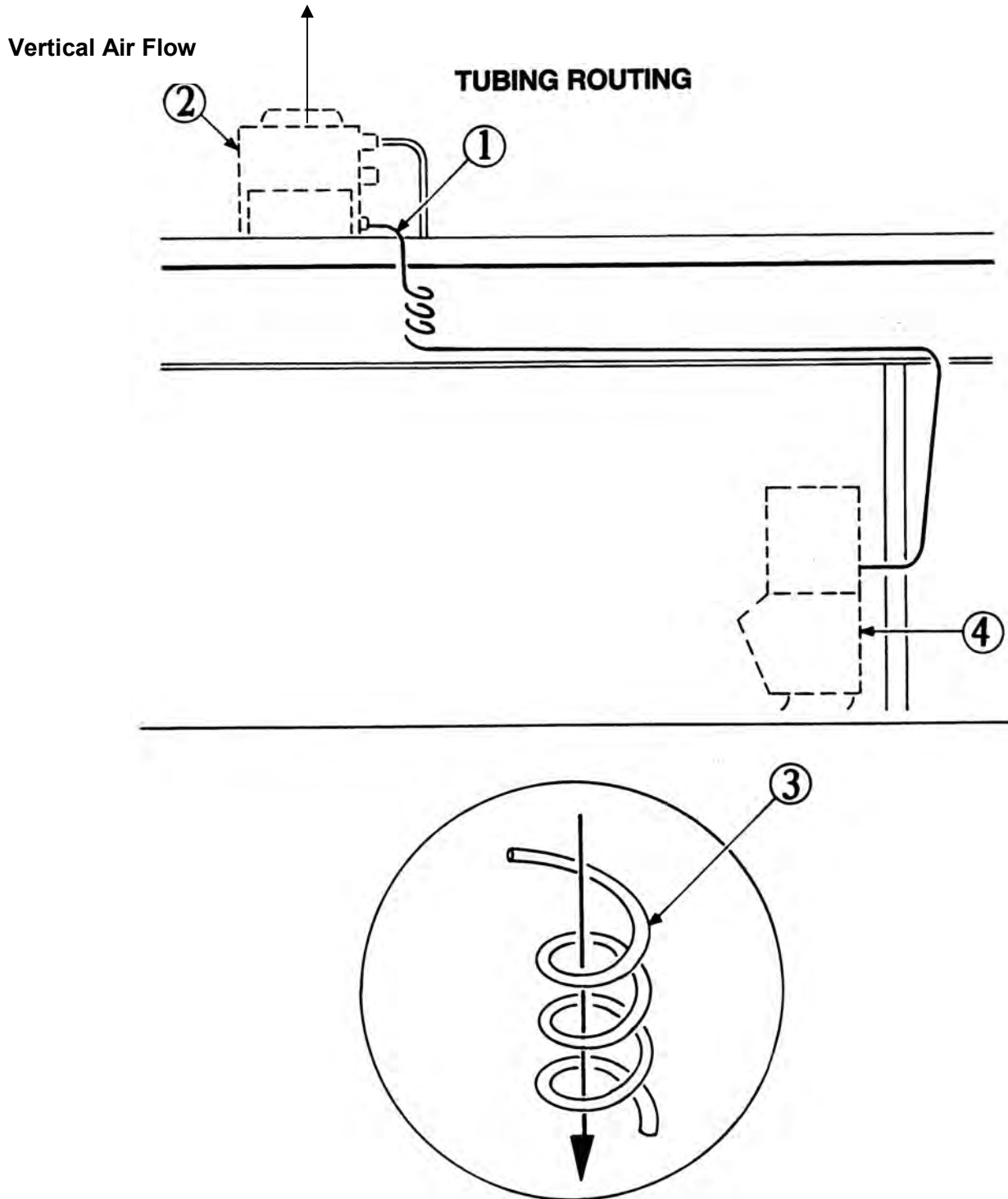

Precharged Line Set Routing

CAUTION: Do not connect the precharged tubing until all routing and forming of the tubing is complete. See the coupling instructions for connecting information.

1. Each set of precharged tubing refrigerant lines consists of a 3/8 diameter liquid line (#5) and a 1/2 inch diameter discharge line (#6). Both ends of each line have quick connect couplings and Schrader valve connections.

Note: The openings in the building ceiling or wall, listed in the next step, are the minimum sizes recommended for passing the refrigerant lines through.

2. Have the roofing contractor cut a minimum hole for the refrigerant lines of 1.750 inch. Check local codes, a separate hole may be required for the electrical power to the condenser.

CAUTION: DO NOT KINK OR CRIMP REFRIGERANT TUBING WHEN INSTALLING IT.

3. Route the refrigerant lines through the roof opening. Follow straight line routing whenever possible. Any excess tubing **MUST** remain within the building.

4. Spiral the excess length of precharged tubing inside the building. Use a horizontal spiral (does not need to be as tight as illustrated) to avoid any traps in the lines.

5. Have the roofing contractor seal the holes in the roof per local codes.

CAUTION: The couplings on the sets of precharged lines are self sealing when installed properly. Carefully follow the instructions:

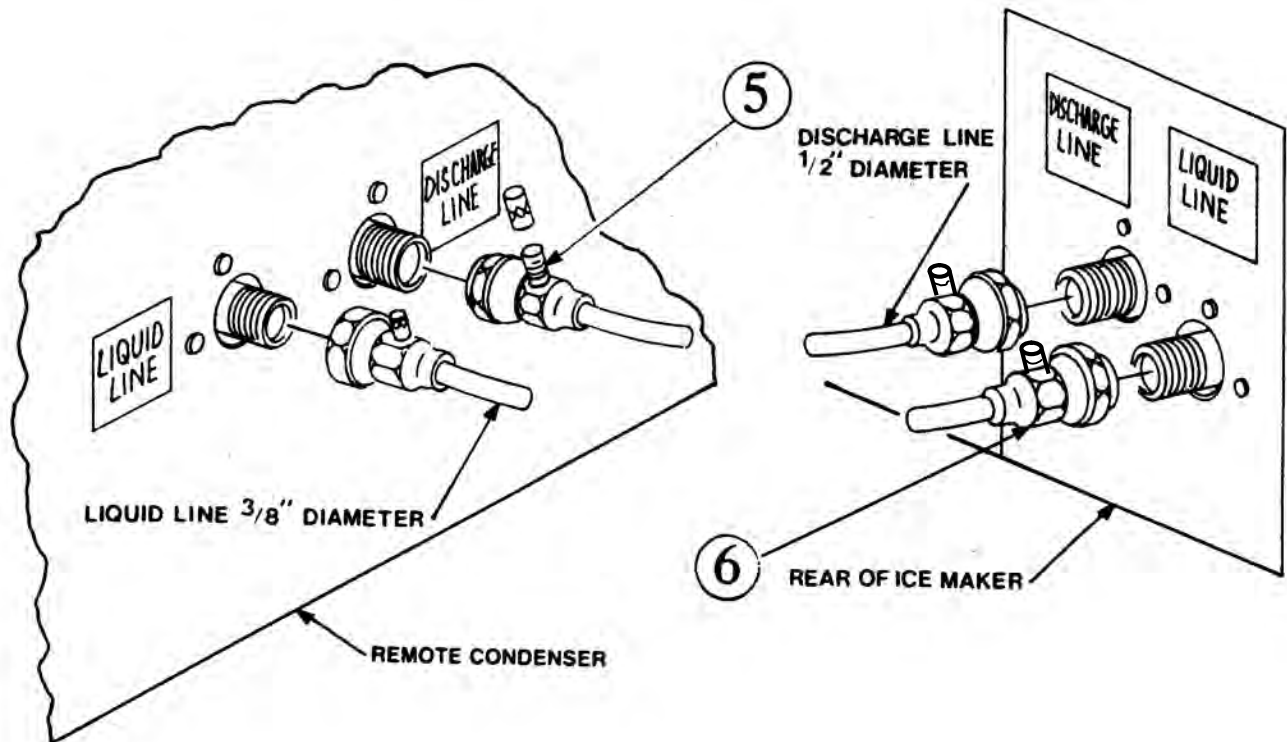

Coupling Instructions:

Initial Connections:

1. Remove the protector caps and plugs. Wipe the seats and threaded surfaces with a clean cloth to be certain that no foreign matter remains on them.
2. Lubricate the inside of the couplings, especially the O-Rings with refrigerant oil.
3. Position the fittings on the correct connections on the remote condenser and ice machine.
 - The 1/2 inch discharge line goes to the remote condenser fitting marked "Discharge Line"
 - The 3/8 inch liquid line goes to the remote condenser fitting marked "Liquid Line".
 - The 1/2 inch discharge line goes to the ice machine fitting marked "Discharge Line".
 - The 3/8 inch liquid line goes to the ice machine fitting marked "Liquid Line".

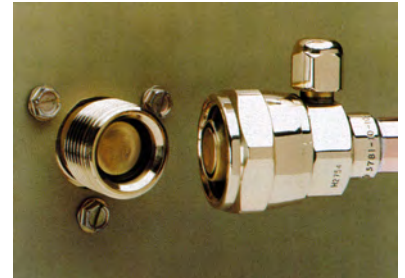

Final Connections:

- 4a. Begin by tightening the couplings together by hand. Continue to turn the swivel nuts by hand until it is certain that the threads are properly engaged.

- 4b. Using two wrenches, one to rotate the swivel nut and one to hold the tubing, tighten each coupling. It is CRITICAL that ONLY the NUT on the precharged tube be turned or the diaphragms will be torn loose by the piercing knives and be loose in the refrigeration system causing severe operational problems.

Note: As the coupling is tightened, the diaphragms in the quick connect couplings will begin to be pierced. As that happens, there will be increased resistance to tightening the swivel nut.

- 4c. Continue tightening the swivel until it bottoms out or a very definite increase in resistance is felt (no threads should be showing). Do **NOT** over tighten.

5. Using a marker or pen, mark a line lengthwise from the coupling union nut to the bulkhead. Then tighten the coupling and additional 1/4 turn. As the nut turns, the line will show when the 1/4 turn is made.

6. After all connections are made, and after the king valve has been opened (do not open at this time) check the couplings for leaks.

