



# Viper™ Elite Classic

## 4 Flavor Frozen Dispenser - Tall

Specification Guide

VIPER™ ELITE CLASSIC



## Features

### Enhanced Reliability

Increase uptime with the most reliable FCB dispenser on the market

### Syrup Flexibility

Pressure transducers ensure you'll be able to perform as syrups change in the future

### Expand Drink Portfolio

Individual barrel flexibility (FCU/FUB) and profile settings

### Intelligent Defrost™

Patented adaptive defrost keeps you up and running during peak demand so you never miss a sale

### Remote Option

Remote and air-cooled condenser options available

### Information At Your Fingertips

Quickly access manuals and easy-to-follow staff and service videos via QR code

### C3 Technology

Cooling, carbonation, and controls provide unmatched drink profile consistency, builds repeat sales and minimizes syrup usage

### Programmable Sleep Mode

Conserves energy in off hours

### Technician Designed

Reduced maintenance and service times

### ADA Compliant

Stainless push handle valve



**MARMON**  
Foodservice  
Technologies

A BERKSHIRE HATHAWAY COMPANY



# Viper™ Elite Classic

## 4 Flavor Frozen Dispenser - Tall

Specification Guide

### Technical Specifications

<b>Electrical Requirements</b>	230V +/- 15V 60Hz, 30a, single phase
	<i>Includes 8ft. power NEMA L6-30P molded plug connection. Part Numbers ending in "EU" and 50HZ SKU's include 8ft. power cord IEC60309 32Amp molded plug connections</i>
<b>Pressure Requirements</b>	CO2 = 75 psig
	Water = 25 min psig dynamic
<b>Draw Capacity</b>	75-82 oz/min continuous, alternating barrels @ 75° F ambient
<b>Refrigation</b>	19,000 BTU, R404A
<b>Agency Listing</b>	 
<b>Clearing Requirements</b>	Top: 12"
	Sides: 2"
	Back: 2"
	<i>The above dimensions are minimum unit clearing requirements</i>
<b>Unit Dimensions</b>	29"W x 32.5"D x 43.7"H
<b>Remote Condenser Unit Dimensions</b>	38.25" W X 32.23" D X 27.60" H
<b>Remote Condenser Operating Temperature</b>	-20°F to 120°F
<b>Graphic Card Dimensions</b>	28.75"W x 18.75"H
<b>Flavor Card Dimensions</b>	6.5"W x 4"H
<b>Shipping Weight</b>	Unit: 500 lbs
	Cart: 200 lbs
	Remote Condenser: 180 lbs

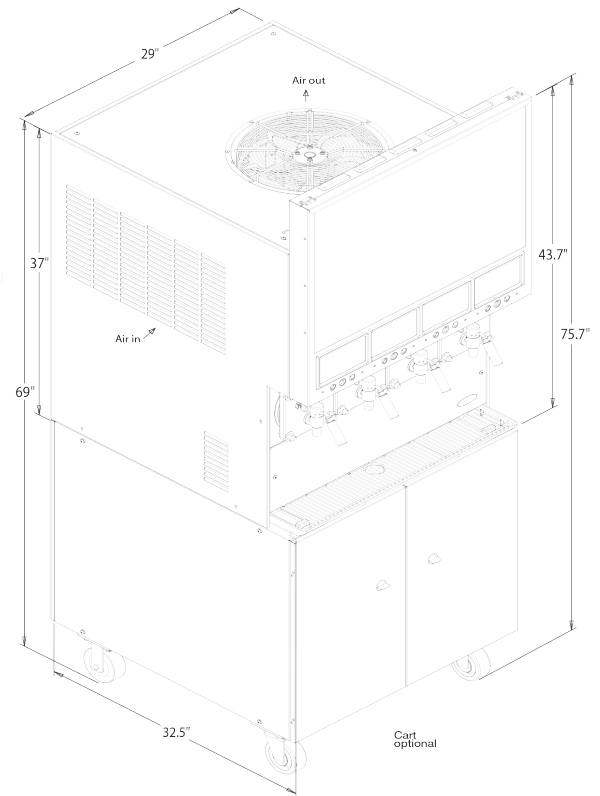

Model Number	Description
621460142	Viper Elite Classic 4 flavor, 230/60Hz, SPH Valve, Tall Merchandiser
621460042	Viper Elite Classic 4 flavor, 230/60Hz, Motorman Valve, Tall Merchandiser
621462142	Viper Elite Classic Remote 4 flavor, 230/60Hz, SPH Valve, Tall Merchandiser*

**\*Note: When ordering the Remote unit, the corresponding accessories below (marked with\*) must also be ordered**

*SPH stands for Stainless Push Handle. For FUB applications, Motorman valves are recommended*

Accessories Number	Description
629087406	Leg kit, 4" legs adjustable to 5.25"
620046556	Viper 4 flavor cart, stainless steel
620046477	Viper 4 flavor generic graphic for tall merchandiser
620042868	Generic flavor card set (includes 18 flavors)
32467400	Buck and boost transformer
620067108	Viper 3 flavor & Viper 4 flavor remote condenser unit for tall merchandiser*
620071967	50ft Line Set 3/8 1/2*
620071969	100ft Line Set 3/8 1/2*

*Refer to Installation Manual for required installation materials*

To learn more and see **Viper™ Elite Classic** in action, visit  
[cornelius.com/product-category/frozen/frozen](http://cornelius.com/product-category/frozen/frozen)  
 To contact us directly, go to [cornelius.com/contact-us](http://cornelius.com/contact-us)