



# Viper™ Low Overrun 4 Flavor Frozen Dispenser - Tall

Specification Guide

VIPER™ LOW OVERRUN



## Features

### Enhanced Reliability

Increase uptime with the most reliable FCB dispenser on the market

### Syrup Flexibility

Pressure transducers ensure you'll be able to perform as syrups change in the future

### Expand Drink Portfolios

Individual barrel flexibility (FCB/FUB) and profile settings. Champions low overrun, slush product consistency

### Intelligent Defrost™

Patented adaptive defrost keeps you up and running during peak demand so you never miss a sale

### Information At Your Fingertips

Quickly access manuals and easy-to-follow staff and service videos via QR code

### C3 Technology

Cooling, carbonation, and controls provide unmatched drink profile consistency, builds repeat sales and minimizes syrup usage

### Programmable Sleep Mode

Conserves energy in off hours

### Technician Designed

Reduced maintenance and service times



# Viper™ Low Overrun 4 Flavor Frozen Dispenser - Tall

Specification Guide

## Technical Specifications

<b>Electrical Requirements</b>	230V +/- 15V 60Hz, 30A, single phase <i>Includes 8ft. power cord NEMA L6-30P molded plug connection.</i>
<b>Pressure Requirements</b>	CO2 = 75 psig Water = 25 min psig dynamic
<b>Draw Capacity</b>	75-82 oz/min continuous, alternating barrels @ 75° F ambient
<b>Refrigation</b>	19,000 BTU, R448A
<b>Agency Listing</b>	 
<b>Clearing Requirements</b>	Top: 12" Sides: 2" Back: 2" <i>The above dimensions are minimum unit clearing requirements</i>
<b>Unit Dimensions</b>	29"W x 32.5"D x 43.7"H (including merchandiser)
<b>Graphic Card Dimensions</b>	28.75"W x 18.75"H
<b>Flavor Card Dimensions</b>	6.5"W x 4"H
<b>Shipping Weight</b>	Unit: 525 lbs Cart: 200 lbs

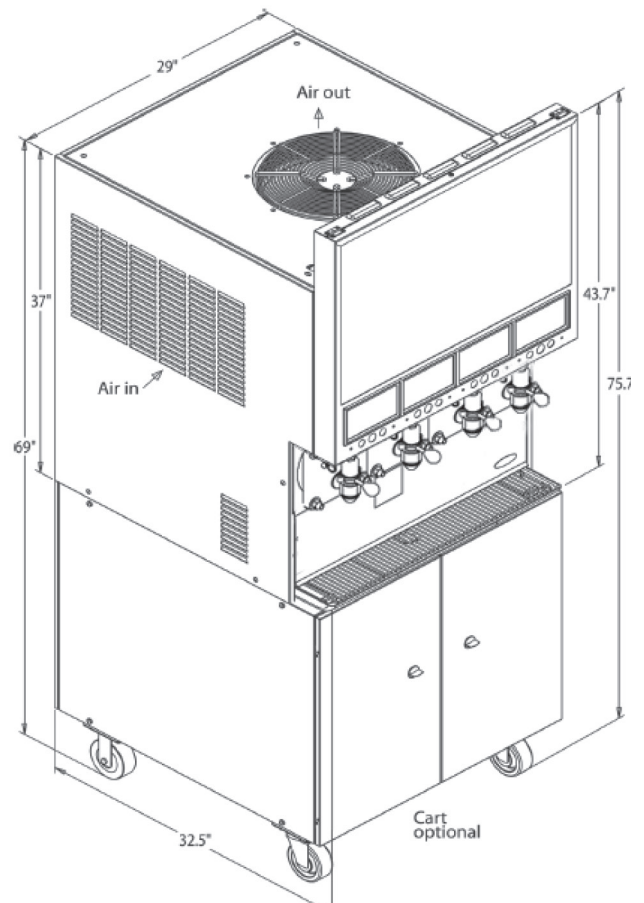

Model Number	Description
621460242LO	Viper Low Overrun Frozen 4 flavor, 230/60Hz, Air Cooled, Full-travel Motorman Valves, Stainless Steel Panels, Tall Merchandiser

Accessories Number	Description
629087406	Leg kit, 4" Height (order 4 per unit)
620046556	Viper Elite 4 Flavor Cart, Stainless Steel Side Panels

Refer to Installation Manual for required installation materials

To learn more and see **Viper™ Low Overrun** in action, visit [cornelius.com](http://cornelius.com)  
To contact us directly, go to [cornelius.com/contact-us](http://cornelius.com/contact-us)