



VIPER™

Viper™

2 Flavor Frozen Dispenser - Tall

Specification Guide



## Features

### High Capacity

Surge capacity dispensing 10 (16oz) consecutive drinks per barrel with a continuous draw capacity of 60-66 fl.oz per minute

### Patented Intelligent Defrost™

Manages product quality and bypasses unnecessary defrost times

### Defrost Lock-Out Times

Schedule defrost lockout times to avoid down time during peak demand periods

### Sleep Mode

Schedule sleep modes to conserve energy during off hours

### QR Code

Quickly access service manuals and easy-to-follow training videos

### C3 Technology

Cooling, carbonation, and controls provide unmatched drink profile consistency and minimizes syrup usage

### Serviceability

Reduced maintenance and service times with a 0.3% out of the box failure rate

### Programmable Flavor Barrels

Individual barrel flexibility and profile settings

### ADA Compliant

Stainless push handle valve



MARMON  
Foodservice  
Technologies

A BERKSHIRE HATHAWAY COMPANY



Viper™

## 2 Flavor Frozen Dispenser - Tall

Specification Guide

### Technical Specifications

<b>Electrical Requirements</b>	230V +/- 15V 60Hz, 20a, Single Phase
	230V +/- 15V 50Hz, 20a, Single Phase
	<i>Includes 8ft. power NEMA L6-30P molded plug connection. Part Numbers ending in "EU" and 50HZ SKUs include 8ft. power cord IEC60309 32Amp molded plug connections - Part numbers ending in "AU" include 56PA33Z plug.</i>
<b>Pressure Requirements</b>	CO2 = 75 psig Water = 25 min psig dynamic
<b>Draw Capacity</b>	60-66 oz/min continuous, alternating barrels @ 75° F (24°C)
<b>Refrigeration</b>	19,000 BTU, R404A
<b>Minimum Clearance Requirements</b>	Top: 12" (305mm) Both Sides: 2" (51mm) -or- Back: 2" (51mm) for temperatures < 90°F (32°C)
<b>Unit Dimensions</b>	17"W x 32.5"D x 43.7"H (431.8mm x 825.5mm x 1109.98mm)
<b>Graphic Card Dimensions</b>	16.75"W x 18.75"H (425.45mm x 476.25mm)
<b>Flavor Card Dimensions</b>	6.5"W x 4"H (165.1mm x 101.6mm)
<b>Unit Weight</b>	390lbs (176.9kg)
<b>Shipping Weight</b>	Unit: 410lbs (186kg) Cart: 175lbs (79.4kg)
<b>Agency Listing</b>	60Hz   
	50Hz  

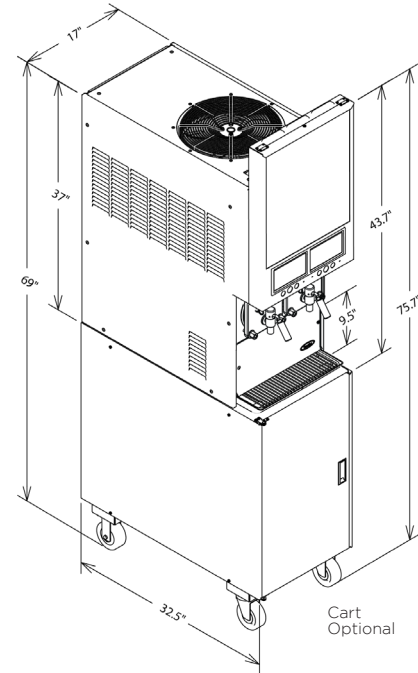

Model Number	Description
621260142	Viper 2 Barrel, 60Hz, Air Cooled, Stainless Push Handle Valve (SPH), Tall Merchandiser, N. American Power Cord
621260042	Viper 2 Barrel, 60Hz, Air Cooled, Motorman Valve, Tall Merchandiser, N. American Power Cord
621250142	Viper 2 Barrel, 50Hz, Air Cooled, Stainless Push Handle Valve (SPH), Tall Merchandiser, IEC Power Cord
621250042	Viper 2 Barrel, 50Hz, Air Cooled, Motorman Valve, Tall Merchandiser, IEC Power Cord
621260142EU	Viper 2 Barrel, 60Hz, Air Cooled, Stainless Push Handle Valve (SPH), Tall Merchandiser, IEC Power Cord
621260042EU	Viper 2 Barrel, 60Hz, Air Cooled, Motorman Valve, Tall Merchandiser, IEC Power Cord

*Not all configurations are available - please contact a Cornelius® expert for additional information  
For FUB, Motorman Valves are recommended*

Accessories Number	Description
629087406	Leg kit, 4" legs adjustable to 5.25"
620043075	Viper 2 barrel cart, stainless steel
620042822	Viper 2 barrel generic graphic for tall merchandiser
620042868	Generic flavor card set (includes 18 flavors)
620051378	Coke flavor card set
620051379	Pepsi flavor card set
324674000	Buck and boost transformer
629096927	Viper 2 barrel installation kit
621056813	Viper 2 barrel pre-plumbed cart
326002000	Drain kit for drip tray

*Refer to Installation Manual for required installation materials - A Buck/Boost transformer is recommended for most installations*

To learn more and see Viper™ in action, visit [cornelius.com](http://cornelius.com)  
To contact a Cornelius® expert today, visit [cornelius.com/contact-us](http://cornelius.com/contact-us)