



# INSTALLATION INSTRUCTIONS

## FOR DF/ED175-8V "K" STYLE LID KITS, P/N 629087902 AND 629087904

These "K" style kits apply to the following ice makers:

**Table 1. Applicable Models**

Ice Maker	Width
Cornelius "I" Series 322/522	22"
Crystal Tips 200/300/400	22"
Ice-O-Matic	22"
Manitowoc 320/420	22"
Scotsman SLC 300/400	22"

**Table 2. Loose Shipped Parts**

Item No.	Part No.	Name	Qty.
1	620043511	Cover, Gray	1
	620043512	Cover, Black	1
2	620043506	Lid Assembly	1
3	22127	Bracket	2
4	70217	#8 Screw	12
5	50904	RTV	1
6	90221	Label	1
7	620919506	Installation Instruction	1
8	620701902	Acorn Nut, 8-32 Nylon	2
9	620701901	Sealing Washer	2
10	620037007	Baffle, Ice DF/ED150	1
11	621701903	#8 Nylon Washer	2
12	620505804	Insulation Strip	1
13	630000408	Thermostat Kit	1

**⚠ WARNING:**

Disconnect power to the unit before installing the adaptor following all lockout/tag out procedures established by the user. Verify that all the power is off to the unit before performing any work.

**Failure to comply could result in serious injury, death or damage to the equipment.**

**⚠ WARNING:**

All ice baffle plates and bin stats, if included or recommended in this kit, must be installed as directed in this manual or the equipment manufacturer's instructions.

**Failure to comply could result in serious injury, death or damage to the equipment.**

**⚠ WARNING:**

All of the attachment screws and plates must be installed as directed in this manual.

**Failure to comply could result in serious injury, death or damage to the equipment.**

Perform the following procedure to install the adapter kit.

1. Unpack the kit.



2. Place insulation strip (Item 12) over studs on the baffle and insert baffle assembly into the adapter lid.
3. Place (2) sealing washers (item 9) over studs and (2) flat washers (item 11), then fasten in place with (2) plastic acorn nuts (item 8).
4. Set ice maker lid on the top of the dispenser.
5. Using the slotted holes in the lid as a template, drill four (4) 0.140" diameter (9/64") holes at the bottom of the slots (see Detail A). Use extreme care not to drill into the hopper. Fasten the lid to the dispenser with four (4) #8 sheet metal screws, two on each side.
6. Seal the ice maker to the top of the dispenser as follows:
  - A. Run beads of RTV around the opening in the lid and inside of the perimeter of the ice maker outline so that the ice maker sets on the RTV.
  - B. Set the ice maker onto the lid and position it as required.
  - C. Wipe away the excess RTV.
7. Drill 9/64" diameter holes into the ice maker cabinet using the bracket as a template. **Use extreme care not to drill into any ice maker components (condenser, tubing, etc.).** Secure the brackets using the screws provided
8. Follow the ice maker manufacturer's instruction to complete the installation of the ice maker including the bin thermostat if so equipped or required.
9. If the plastic acorn nuts interfere with the positioning of the plastic manual fill cover, it may be necessary to make small notches in the back flange of the cover to clear the acorn nuts.

**NOTE: Bin thermostat must not interfere with the agitator rotation.**

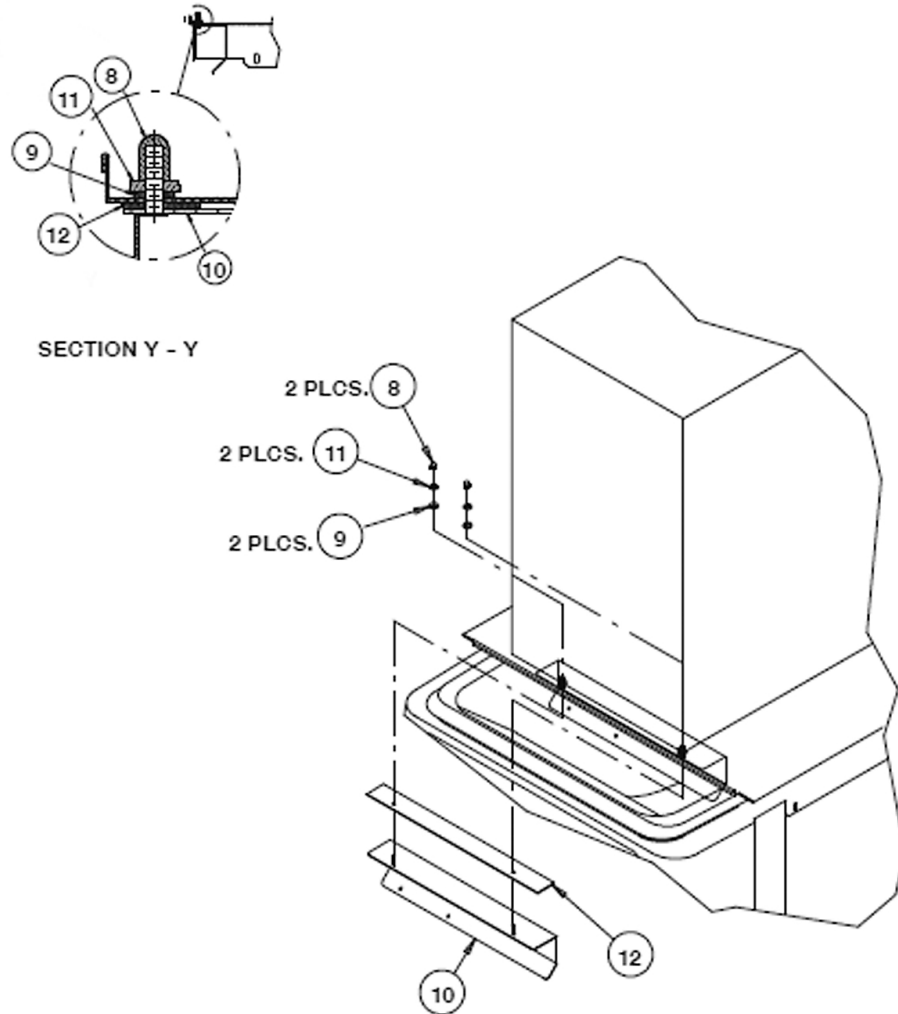

Figure 1. DF/ED175-8V Kit

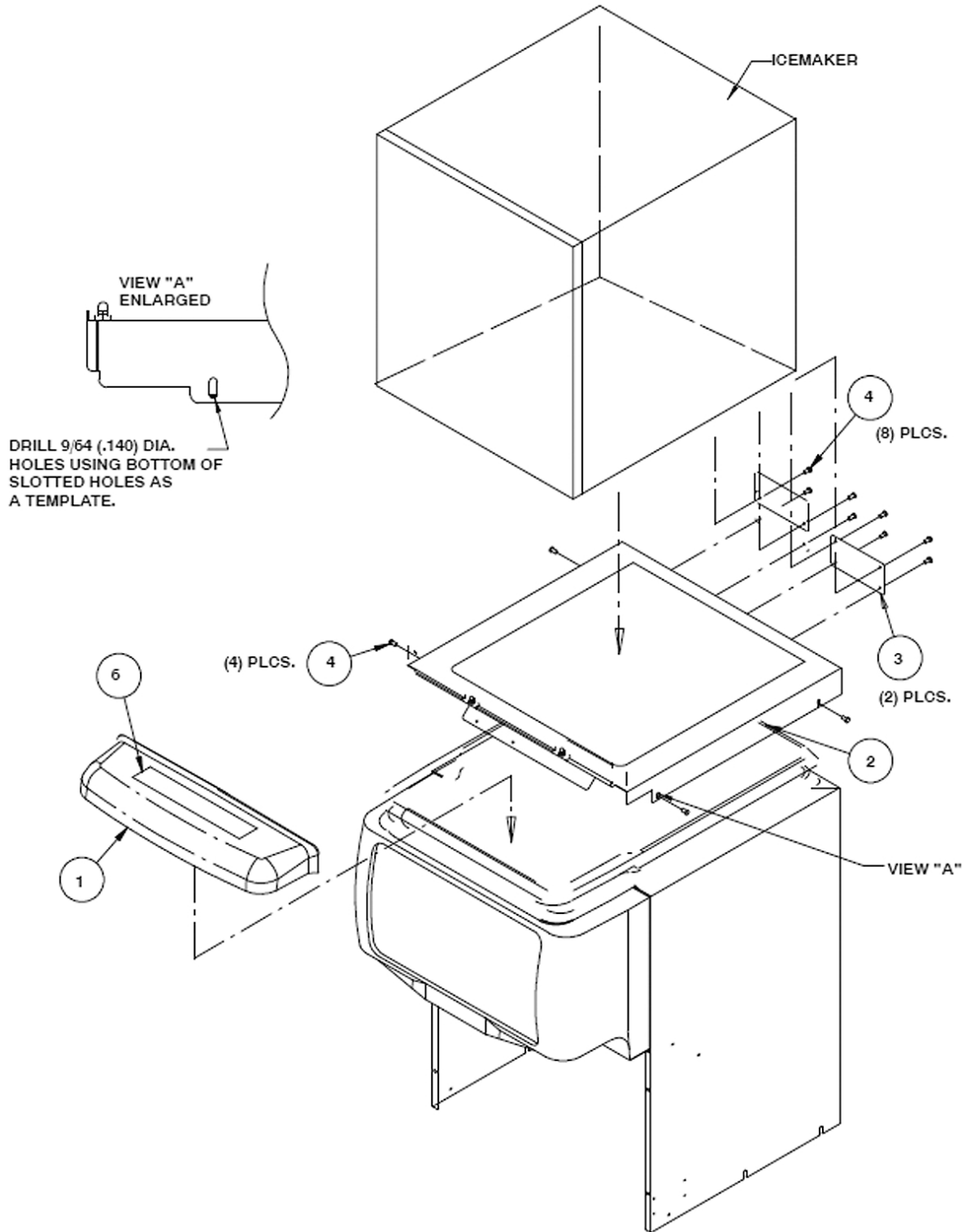

Figure 2. Dispenser Assembly