

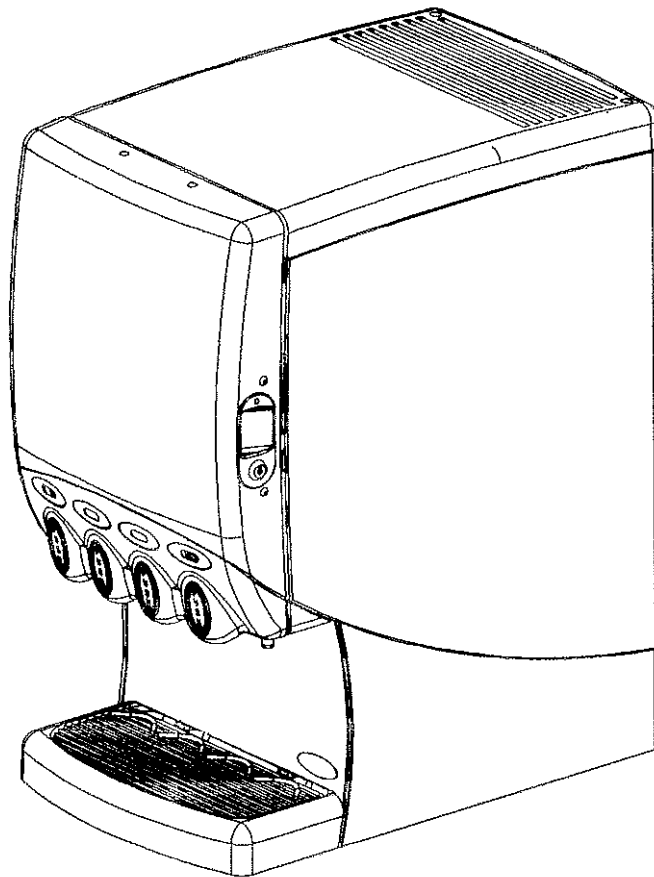

QUEST 4000

Installation Manual



Release Date: August 17, 2006
Publication Number: 720901117INS
Revision Date: April 25, 2014
Revision: F

Visit the Cornelius web site at www.cornelius.com for all your Literature needs.

The products, technical information, and instructions contained in this manual are subject to change without notice. These instructions are not intended to cover all details or variations of the equipment, nor to provide for every possible contingency in the installation, operation or maintenance of this equipment. This manual assumes that the person(s) working on the equipment have been trained and are skilled in working with electrical, plumbing, pneumatic, and mechanical equipment. It is assumed that appropriate safety precautions are taken and that all local safety and construction requirements are being met, in addition to the information contained in this manual.

This Product is warranted only as provided in Cornelius' Commercial Warrant applicable to this Product and is subject to all of the restrictions and limitations contained in the Commercial Warranty.

Cornelius will not be responsible for any repair, replacement or other service required by or loss or damage resulting from any of the following occurrences, including but not limited to, (1) other than normal and proper use and normal service conditions with respect to the Product, (2) improper voltage, (3) inadequate wiring, (4) abuse, (5) accident, (6) alteration, (7) misuse, (8) neglect, (9) unauthorized repair or the failure to utilize suitably qualified and trained persons to perform service and/or repair of the Product, (10) improper cleaning, (11) failure to follow installation, operating, cleaning or maintenance instructions, (12) use of "non-authorized" parts (i.e., parts that are not 100% compatible with the Product) which use voids the entire warranty, (13) Product parts in contact with water or the product dispensed which are adversely impacted by changes in liquid scale or chemical composition.

Contact Information:

To inquire about current revisions of this and other documentation or for assistance with any Cornelius product contact:

www.cornelius.com

800-238-3600

Trademarks and Copyrights:

This document contains proprietary information and it may not be reproduced in any way without permission from Cornelius.

Printed in U.S.A.



TABLE OF CONTENTS

Safety Instructions	1
Read and Follow ALL Safety Instructions	1
Safety Overview	1
Recognition	1
Different Types of Alerts	1
Safety Tips	1
Qualified Service Personnel	1
Safety Precautions	2
Shipping And Storage	2
Mounting in or on a Counter	2
Requirements	3
Nameplate Data	3
Concentrate Storage	3
Recommended Clearance	3
Electrical Connection	3
Power Supply	3
Water Connection	3
Water Supply Requirements	4
Ice Bank/Pull Down	4
Receiving	4
Unpacking	4
Counter Location	4
Filling the Ice Bath	5
Connecting Water Supply	5
Electrical	6
Priming/Flushing Water System	6
Programming the Portion Control	6
Cancel/Pour Button	6

SAFETY INSTRUCTIONS

READ AND FOLLOW ALL SAFETY INSTRUCTIONS

Safety Overview

- Read and follow **ALL SAFETY INSTRUCTIONS** in this manual and any warning/caution labels on the unit (decals, labels or laminated cards).
- Read and understand **ALL** applicable OSHA (Occupational Safety and Health Administration) safety regulations before operating this unit.

Recognition



DIFFERENT TYPES OF ALERTS

DANGER:

Indicates an immediate hazardous situation which if not avoided **WILL** result in serious injury, death or equipment damage.

WARNING:

Indicates a potentially hazardous situation which, if not avoided, **COULD** result in serious injury, death, or equipment damage.

CAUTION:

Indicates a potentially hazardous situation which, if not avoided, **MAY** result in minor or moderate injury or equipment damage.

SAFETY TIPS

- Carefully read and follow all safety messages in this manual and safety signs on the unit.
- Keep safety signs in good condition and replace missing or damaged items.
- Learn how to operate the unit and how to use the controls properly.
- **Do not** let anyone operate the unit without proper training. This appliance is **not** intended for use by very young children or infirm persons without supervision. Young children should be supervised to ensure that they do not play with the appliance.
- Keep your unit in proper working condition and do not allow unauthorized modifications to the unit.

QUALIFIED SERVICE PERSONNEL

WARNING:

Only trained and certified electrical, plumbing and refrigeration technicians should service this unit. **ALL WIRING AND PLUMBING MUST CONFORM TO NATIONAL AND LOCAL CODES. FAILURE TO COMPLY COULD RESULT IN SERIOUS INJURY, DEATH OR EQUIPMENT DAMAGE.**

SAFETY PRECAUTIONS

This unit has been specifically designed to provide protection against personal injury. To ensure continued protection observe the following:

WARNING:

Disconnect power to the unit before servicing following all lock out/tag out procedures established by the user. Verify all of the power is off to the unit before any work is performed.

Failure to disconnect the power could result in serious injury, death or equipment damage.

CAUTION:

Always be sure to keep area around the unit clean and free of clutter. Failure to keep this area clean may result in injury or equipment damage.

SHIPPING AND STORAGE

CAUTION:

Before shipping, storing, or relocating the unit, the unit must be sanitized and all sanitizing solution must be drained from the system. A freezing ambient environment will cause residual sanitizing solution or water remaining inside the unit to freeze resulting in damage to internal components.

MOUNTING IN OR ON A COUNTER

WARNING:

When installing the unit in or on a counter top, the counter must be able to support a weight in excess of 189 lbs. (85.7 kg.) to insure adequate support for the unit. **FAILURE TO COMPLY COULD RESULT IN SERIOUS INJURY, DEATH OR EQUIPMENT DAMAGE.**

REQUIREMENTS

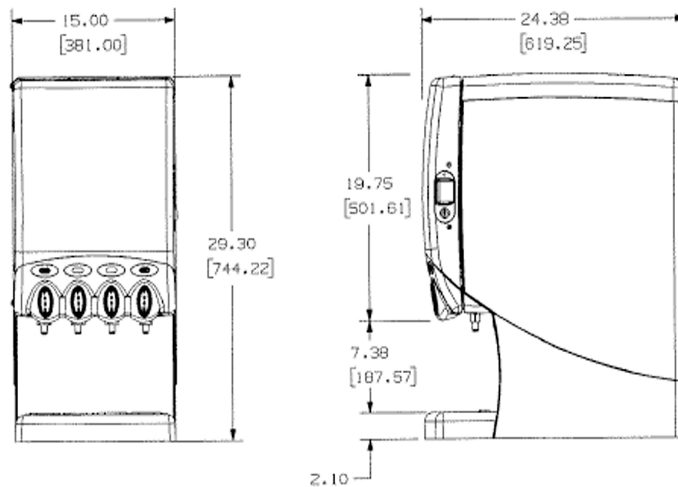

Figure 1. Unit Dimensions

Nameplate Data

Model QST 4000, 115 VAC, 4.5 amps, 1 phase 60 hertz, 6.75 oz. (191-193g) R-134a refrigerant. Test press: High side 400 psi (27.6 bar). Low side 100 psi (6.9 bar).

Model QST 4000,230 VAC, 3 amps, 1 phase 60hertz, 6.75 oz. (191-193g) R-134a refrigerant. Test press: High side 400 psi (27.6 bar). Low side 100 psi (6.9 bar).

Concentrate Storage

Four 0.8 gallon (3.0 liter) disposable bottles.

Recommended Clearance

12" (30.48 cm) on top and 4" (10.16 cm) required in back for air circulation.

Electrical Connection

6 ft. long (1.83 m) power cord with 3-prong plug attached to dispenser. Export models have a line cord less plug.



CAUTION:

ONLY trained and certified electrical technicians should replace the power cord or the unit should be returned to an Authorized Service Center for power cord replacement." The replacement cord must meet all requirements of the original equipment manufacturer.

Failure to comply could result in serious injury, death or damage to the equipment.

Power Supply

15 amps at 120 volts dedicated power supply.

20 amps at 230 volts dedicated power supply.

Water Connection

3/8 in. (0.95 cm) SAE male flare fitting on dispenser.

The new hose sets supplied with the appliance are to be used and that old hose sets should not be reused.

Water Supply Requirements

60 psi (413.7 kilopascals) (4.1 bar) maximum static pressure. 30 psi (206.8 kilopascals) (2.1 bar) minimum dynamic pressure; i.e., flowing pressure measured at dispenser water inlet with 3.0 (88.7 ml) per second water flow. Optimum recommended pressure 50 psi (344.7 kilopascals) (3.5 bar) dynamic pressure.

Ice Bank/Pull Down

Weight 14-16 lbs. Pull Down: 3.5 - 5 hours at 75°F (24°C)

RECEIVING

Each unit is completely tested and inspected before shipment. At the time of shipment, the carrier accepts the unit and any claim for damage must be made with the carrier.

Upon receiving the unit(s) from the carrier, inspect the carton for visible damage. If damage exists, have the carrier make a note on the bill of lading and file a claim with the carrier.

UNPACKING

- Remove staples securing carton to pallet.
- Lift carton up and off of unit.
- Remove inserts and shipping bag.
- Open upper cabinet door and remove installation kit.
- Remove bolts securing unit to pallet.
- Lift unit off of pallet.

NOTE: Do not lay the unit on it's side or back. This may cause vital oils to drain from the compressor resulting in damage during start-up and consequently voiding the warranty.

COUNTER LOCATION

Select a location in a well ventilated area, close to a grounded electrical outlet. If possible do not place the unit close to hot and/or steaming machines.

The minimum airflow clearance is: 4" (10.16 cm) in back and 12" (30.48 cm) on top and open to the front.

IMPORTANT: Condenser air is drawn in from the bottom of the rear panel and discharged out the top of the rear panel. Failure to maintain clearance space will reduce capacity of the unit and cause premature compressor failure.

Typically the dispenser is placed directly on the counter and a food grade silicone sealant applied around the base. However, supplied with the dispenser is a counter top sealing gasket. This eliminates the need for sealant and is much easier to use.

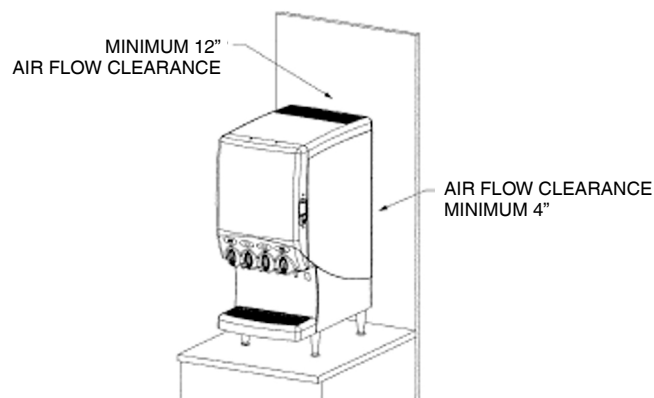

Figure 2. Minimum Clearances

FILLING THE ICE BATH

The ice bath holds approximately 3 gallons (11.4 liters) of water. The fill tube is located behind the front splash plate and capped with a 3/8" (0.95 cm) male flare connector. Prior to attaching the water supply line to the dispenser, use it to fill the ice bath by attaching it to the connector on the fill tube.

Slowly open the water shut off valve and fill the ice bath until water trickles from the overflow. This is the quickest and easiest way to fill the ice bath.

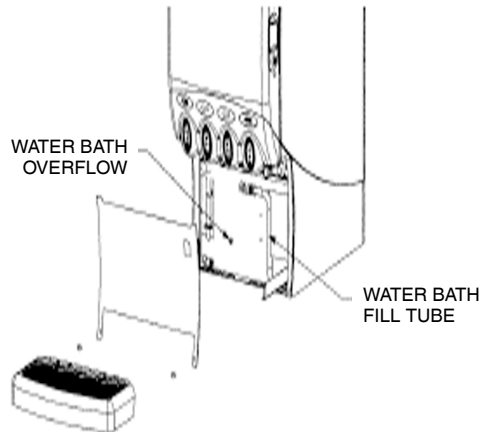

Figure 3. Filling the Water Bath

Once the ice bath is full, store the fill tube in the vertically recessed holder. The fill tube can now be used as a "sight glass" to monitor the water level in the ice bath.

CONNECTING WATER SUPPLY

The QST series Juice Dispenser is designed to dispense juice at a high flow rate. It is very important that the incoming water line be dedicated for use by the dispenser only and does not have other machines connected which could cause a water surge, (i.e., a dishwasher, coffee maker, etc.).

IMPORTANT: The water supply should be consistent with proper water quality standards (neutral pH of 7.0 to 8.0), and should not be connected to a water softener. It is the installer's responsibility to ensure that all water connections to the dispenser are sized, installed with adequate backflow protection and maintained to comply with Federal, State, and Local Laws.

1. Secure the 3/8" (0.95 cm) swivel nut on the flexible supply tubing to the water inlet located at the rear of the dispenser. Make sure that the flared gasket is used (flared gasket is included with the installation kit).



Figure 4. Water Supply Connection

2. When securing flare nut, use a backup wrench on the male side of the inlet fitting (unit side) to prevent twisting of the copper tube inside the unit and/or possible damage to the water strainer/solenoid. Water shut off outside the unit is recommended.



WARNING:

This equipment must be installed to comply with the International Plumbing Code of the International Code Council and the Food Code Manual of the Food and Drug Administration (FDA). For models installed outside the U.S.A., you must comply with the applicable Plumbing/Sanitation Code for your area.

Failure to comply could result in serious injury, death or damage to the equipment.

ELECTRICAL

A minimum of 15 amps electrical service is needed for 120VAC power supply.

A minimum of 20 amps electrical service is needed for 230VAC power supply.

PRIMING/FLUSHING WATER SYSTEM

To properly prime the unit with water and remove air pockets in the system, open the cabinet door and make sure that all the valve levers are in the **Dispense** position.

Close the door and press the dispense button for a few seconds. Repeat until a steady flow of water is observed from all dispense valves.

NOTE: Some splashing may occur during this purge cycle.

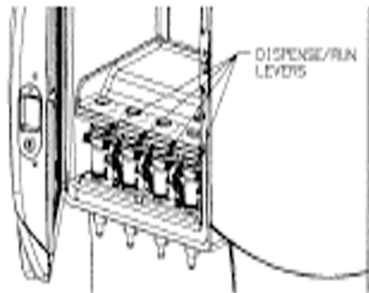

Figure 5.



PROGRAMMING THE PORTION CONTROL

If the dispenser has optional portion controls, they have been pre-programmed from the factory to pour 7, 12, and 16 ounce drinks. The “extra large” (pitcher icon) size has also been pre-programmed to pour 16 ounces. To change the pour sizes, please perform the following procedure.

Table 1

Step	Action
1	Simultaneously, press and hold Small and Extra Large (pitcher icon) buttons on the Portion Control Module until the Refill light starts blinking. Release the buttons. The blinking Refill light indicates the programming mode is active.
2	Place a cup under the dispense nozzle and push the selected size button (small, medium, large, or extra large). Hold the button in until the cup fills to the desired portion, then release the button. Repeat the procedure for the remaining sizes.
3	After programming all the drink sizes, press and release the Cancel/Pour button to return the Portion Control to the operational mode. The blinking REFILL light goes off.
4	In the future, to change the portion size of the drinks, the individual sizes can be adjusted by performing Step 2. It is not necessary to reprogram every size. Additionally, the portion control has full memory retention in case of a power failure.



CANCEL/POUR BUTTON



To pour a drink without using a pre-programmed portion control size, simply push and hold the Stop button. Release when the glass is full.

Cornelius Inc.
www.cornelius.com