



JETSPRAY™ MODEL J15

15 GALLON SINGLE-FLAVOR
VISUAL DISPLAY DISPENSER



FEATURES

Large capacity - 15 gal (57 L) capacity

Efficient - Ideal for high-volume, quick service operations

Small footprint - Maximum profit from a minimum space; only 16" (40.5 cm) wide

Merchandising - Self-merchandising visual display creates impulse sales

Accommodating - Available tall cup kit can accommodate large cup size, up to 64 oz

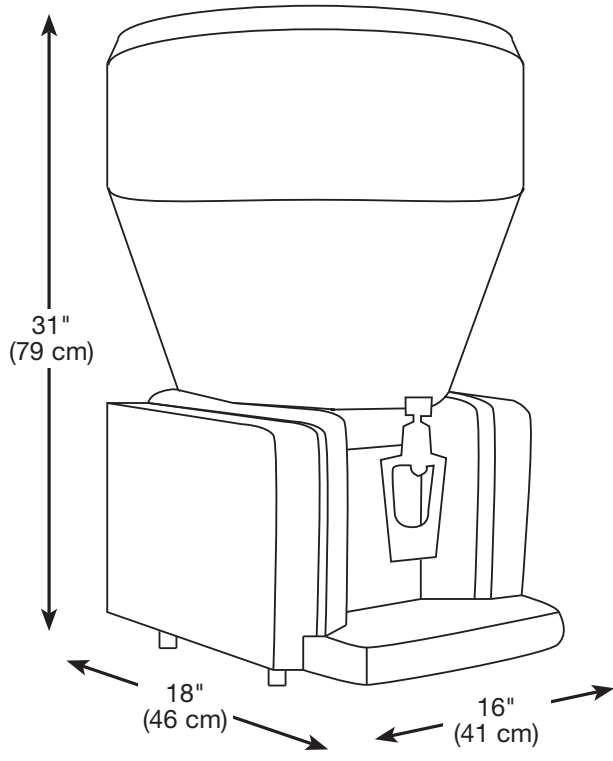

PART NUMBER	DESCRIPTION
J15	Cold Beverage Dispenser J15, Visual Single Bowl, 15 Gallon Spray Type, 115V / 60Hz

TECHNICAL SPECIFICATIONS

BEVERAGE BOWL & COVER Transparent, virtually unbreakable LEXAN® resin

BOWL DIAMETER 20" (50.8 cm)

CABINETY White plastic and stainless steel

BEVERAGE CAPACITY 15 gal (57 L)

CUP CLEARANCE 9"

REFRIGERATION JetSpray 1/4 HP hermetically sealed system R134a

NET WEIGHT 61 lb (28 kg)

SHIPPING WEIGHT Bowl: 17 lb (8 kg)
Base: 62 lb (28 kg)

CARTON VOLUME Bowl: 7.2 cu ft (0.20 cuM)
Base: 3.8 cu ft (0.11 cuM)

AGENCY LISTINGS   

