

JETWAY

OWNER'S MANUAL FOR Visual Display Dispenser

J15

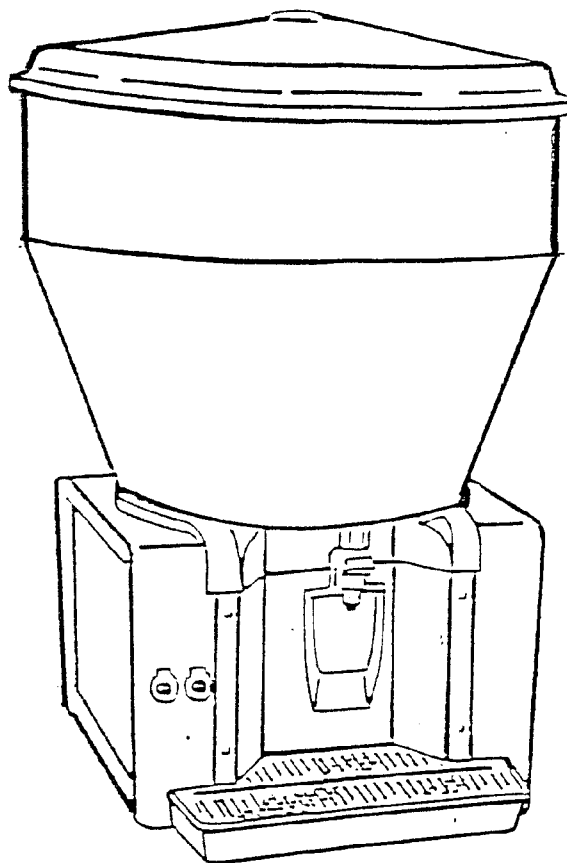

MODEL

J15 (USA)
J15-W25 (Export)
J15-W26 (Export)

Refrigerant R134a

Manufactured by IMI Cornelius/Jet Spray Corporation
2401 N. Palmer Drive, Schaumburg, IL 60196

Phone	U.S. & Canada	1-888-248-5568
	Outside U.S.	1-630-539-5050
Fax	U.S. & Canada	1-800-344-3801
	Outside U.S.	1-630-539-6960

September 1995
Printed in the U.S.A.

Document No. 18482
Revision No. 02

General Description

The EJ1 dispenser is an eight gallon countertop visual display action beverage dispenser. It is designed to dispense a variety of products.

- Warning:**
1. This appliance must be earthed.
 2. This appliance is not suitable for use by unsupervised children.

Location

Place the dispenser on a solid, level surface with not part of the unit extending beyond the edge of that surface.

Power and Water

The J15 requires a 120 Volt, 60 Hz grounded receptacle for the unit's power cord.

The J15-W25 requires a 220V/240V, 50 Hz earthed receptacle for the units power cord.

The J15-W26 requires a 208V/230V, 60 Hz earthed receptacle for the units power cord plug to go into.

Note: *If the colors of the wires in the main leads of this appliance do not correspond with the colored markings identifying the terminals in your plug, proceed as follows.*

-The green and yellow wire must be connected to the terminal in the plug marked with any of the following:

- the letter E
- colored green
- the earth symbol
- colored both green and yellow

- The blue wire must be connected to the terminal in the plug marked with the letter N or colored blue.
- The brown wire must be connected to the terminal in the plug marked with the letter L or colored orange.

Power Cord

If a power cord becomes damaged, do not attempt to repair it. Take the unit to an authorized service agent as a special tool is required.

<u>Area</u>	<u>JS P/N</u>
UK	A5291
USA	S1249
INTERNATIONAL	A1632

Operating Adjustments

Warning: Dangerous voltages are still present within the unit even if the power switch is turned off. Before attempting any adjustments inside the unit, turn the unit off and unplug it from the electrical receptacle.

Notes:

Attention is drawn to the requirements of National Regulations about connecting to and using Potable water supplies. Jet Spray dispensers conform to the requirements of the Model Water Bylaws of 1986 SI 1147. All surfaces which come into contact with food or drinking water are constructed of food quality non-toxic materials, are non-corrosive, non-tainting and do not support the growth of bacteria.

Jet Spray Corporation reserves the right to make changes in design and/or engineering without notice.

Specifications

J15 Series

A. Electrical

Model	P/N	Electrical Supply	RLA	Running Power	LRA
J15	A8661	120VAC, 60 Hz	6.3 AMPS	756 Watts	28 AMPS
J15-W25	A8662	230 VAC, 50 Hz	2.7 AMPS	621 Watts	14 AMPS
J15-W26	A8663	220VAC, 60Hz	3.1 AMPS	682 Watts	14 AMPS

RLA - Running Load Amperage

LRA - Locked Rotor Amperage (*compressor starting amperage*)

B. Class of Windings

Compressor Motor - Class H (*climatic rating; normal*)

Condenser Fan Motor - Class B

C. Environment

Temperature

Operating: 60°F (16°C) to 110°F (43°C)

Storage: Above - 20°F (-7°C) with bowl empty and dry.

Humidity - Below 95%

D. Refrigeration (*R134a refrigerant*)

Model Charge Quantity

J15 175 grams (6.2 oz)

J15-W25 170 grams (6.0 oz)

J15-W26 175 grams (6.2 oz)

Installation and Operating Instructions

Setting up your J15

1. Drip tray and drip tray cover are packed in dispenser base carton.
2. Bowl assembly, cover, bowl gasket, spray tube, impella, pinch tube, and push handle are packed in separate bowl carton. Don't overlook them.
3. Save all packing material and note relationship of parts as you remove them. You may need to move your dispenser to a different location or possibly ship it to you Jet Service Station. It will not pack as well, or as safely, in anything other than these cartons.
4. Connection of fill line for units equipped with inlet water fitting for filling bowl.
 - a. To ease filling the 15 gallon bowl, a $\frac{3}{8}$ " male flare inlet fitting is provided. Connect the fill line to the inlet fitting located on the left-hand bottom of the unit.
 - b. When adding water only, note level using bowl markers. Open line water valve and add appropriate amount of water for size and ratio of syrup; e.g., 5 gallons of water for 1 gallon of 5:1 syrup mix.
5. Be sure dispenser has adequate free space on both sides; approximately 3" away from any wall.

Note: 90° nickel plated brass water fitting (A5878) is available.

Installation of Push Handle

1. With one hand, pull out locating pin (found on the bowl spout) as far as possible.
2. With the other hand, grasp push handle and push handle support spout. Slip push handle support spout over bowl spout and locating pin. Push pin into position.

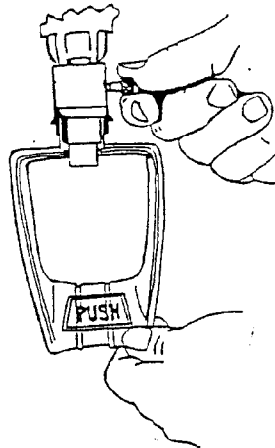

Fig. 1

Installation of Pinch Tube

1. Remove tube from plastic bag and wash with warm water and mild soap or detergent such as Joy.
2. Before installing, wet bowl spout surface and sealing rings on pinch tube. With one hand, push back handle. *See below.*

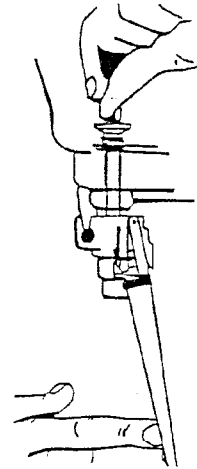
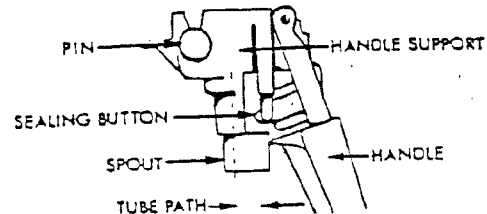

Fig. 2

3. With your other hand, pick up pinch tube as shown in sketch and carefully insert tube into bowl spout opening and on into lower opening of handle support spout. Make sure the end of the tube does not get caught on the edge above the handle support spout opening. Using your thumb, push pinch tube into bowl spout opening. When the end of the tube passes beyond the bottom of the handle support spout opening, pull the end of the tube top into the bowl spout seat. *Make sure tube is free of wrinkles.* The tube should extend about $\frac{1}{4}$ " below the handle support spout.

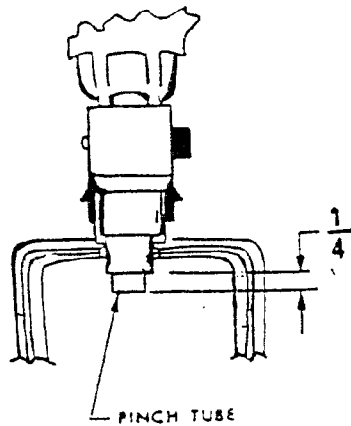

Fig. 3

4. Release the handle.

Removing the Pinch Tube

1. With one hand, push back handle to stop. With the other hand, grasp ring on the top of the pinch tube and lightly pull from the bowl spout.

Removing the Push Handle

1. With one hand, pull out the locating pin as far as possible.
2. With your other hand, grasp handle and pull straight down.

Assembling the Impella & Spray Tube

1. Lock spray tube into the impella assembly as shown in the sketch below.
2. Lock the spray tube into the pump cover. Use warm water on pump cover to ease insertion or removal of spray tube. (See sketch)

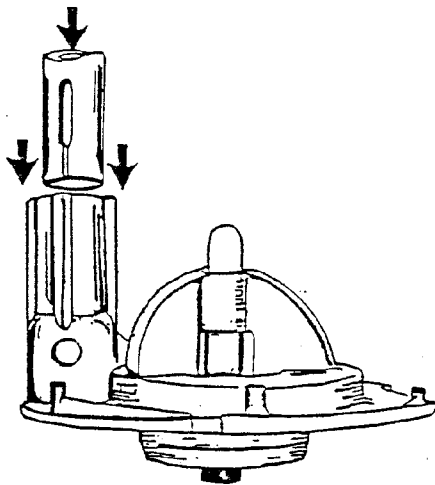

Fig. 4

3. Push the impella support pin through the impella and up through the center hole of the pump housing. Insert retaining clip.

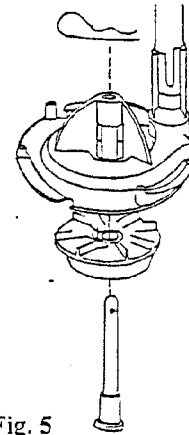

Fig. 5

4. Line up the lines on the pump cover base of the bowl. Drop the pump cover in so that the three tabs on the bowl base go through cut-outs in the pump. Turn pump counterclockwise until tabs of the bowl hit tabs of the cover.

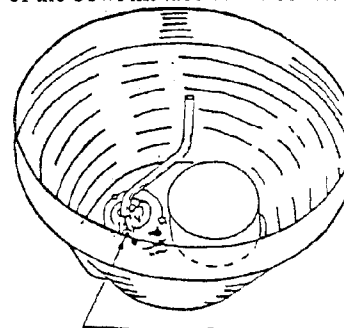

Fig. 6

Operating Procedures

1. Follow beverage manufacturer's directions in filling bowl. To aid in filling, the bowl has gallon and liter markers up the center of the front wall -- gallons on left, liters on right. For units equipped with inlet water valve, see page 1 A4.
2. Snap on the refrigeration and spray switches. Product should be cold enough to serve in 2 hours. Switch should be left "on" 24 hours a day to insure efficient operation.
3. The thermostat is preset at the factory and will not normally require resetting by owner.

Frequent Maintenance Procedures

Cleaning the Bowl

1. Before removing the bowl, turn off the switch.
2. Remove pinch tube by pushing handle until it stops. Pull up on pinch tube until it is free, then remove handle (see pg. 2). Lift off bowl, drip tray, and cover, and clean.
3. Clean as described in Paragraph B "Cleaning the Dispenser".
4. After cleaning, assemble as described in Paragraph C. Replace push handle, and insert pinch tube into bowl.

Sanitizing Unit

1. After cleaning, add one gallon of water between 75°F and 100°F to bowl. Mix one table spoon of approved powdered chlorine sanitizer* in a pint of water and when dissolved, pour into bowl. Replace lid and run unit two or three minutes. Then shut off unit and drain contents through valve.

Ventilation

1. Air flow is essential. Allow at least 3 inches of space on back and sides of dispenser. Lint or dust collecting on the condenser will result in poor refrigeration. Remove the right side panel to clean the condenser. Clean often. Shut off both switches to prevent dirt from flying when cleaning.

Note: The J15 temperature control is located inside of the left-hand perforated side panel (viewed from the valve end of unit).

Cleaning the Filter and Condenser

1. Turn off switch.
2. Remove back panel screws, then back panel, by pulling out on bottom of it.
3. Clean condenser with vacuum cleaner or brush making sure not loose dirt goes into the dispenser.
4. Clean filter by running a stream of hot water through it. Filter need not be removed from grill to do this. Allow to dry before replacing.
5. Replace back panel, putting top edge up under condensate tray and push in on bottom. Re-install back panel screws.

No Spray

1. Be sure switch is "on".
2. If the unit does not spray, remove pump housing and check the impella. The impella must spin freely.
3. Remove the impella and the impella pin at the bottom of the impella. Separate parts and clean.
4. Reassemble. If the impella blades rub on the pump cover, replace with new assembly.

Note: Switch must be "off" when inserting the pump housing assembly into the bowl to assure magnetic coupling.

5. The impella is seldom defective. If the impella magnet has been dropped, examine for damage. If damaged or binding, replace the impella pin and/or the impella magnet.
6. Long pieces of pulp may partially plug the pump housing and bind the impella blades. Juices with excessive pulp must be strained in order to spray.
7. However, if it is desired to retain pulp, then use Jet Spray Circulator Kit No., S6737 in place of the pump housing assembly. Wash sediment from the pump well.
8. The impella assembly should be locked under all three of the bowl lugs. If any of the lugs are broken, the impella will not spray properly, will vibrate, and become noisy. Replace the bowl.
9. Spray drive motor with spray switch "ON" must run in counterclockwise direction. Motor stopped or not up to speed will affect circulation temperature of drink and efficiency of the unit. Replace the spray switch or the drive motor.

Bowl Leaks

1. Do not confuse drippings from condensation on the outside of the bowl as bowl or facet leaks. High humidity causes a greater degree of condensation. Condensation will occur on the sides and undersides of the bowl and will drain into the drip tray. If the bowl is cracked, it will leak beverage. Replace the bowl.
2. Be sure the gasket has been assembled properly. Before removing the bowl, wait 10 minutes after shutting off the refrigeration system to allow time for the ice beneath the bowl gasket to melt. Check gasket for tears or cuts in rubber as they cause leaks.

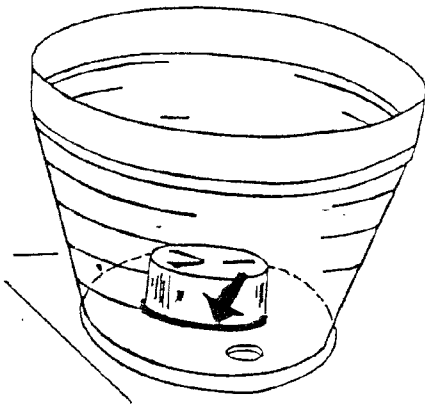

Fig. 7

3. Remove and examine pinch tube for holes. Make sure the pinch tube is properly seated in spout and is free of wrinkles. Pinch tube may occasionally stick shut due to dried syrup inside the tube after a prolonged time of not being used. To open, merely push back handle and pull lightly on the tube outlet. This will open the tube. Frequent washing of the tube will minimize this.

Valve Leaks or Compressed Pinch Tube

1. Make sure pinch tube is properly seated in spout and is free of wrinkles.
2. Pinch tube may occasionally stick shut due to dried syrup inside the tube after a prolonged time of not being used, such as over a weekend. To open, merely push back handle and pull lightly on tube outlet. This will open the tube. Frequent washing of the tube will minimize this problem.

Installation of Bowl Circulator Kits

The bowl circulators are ideal for mixing and circulating beverages which are heavy in pulp or which tend to foam excessively when used with a conventional spray unit. When the circulator is properly placed in the bowl, it ideally mixes and cools the beverage at all levels. These circulators are used in place of the spray pump assemblies.

Part #S6737

1. Remove present pump and spray tube from the bowl (*if equipped*).
2. Place circulator assembly in pump well, located in bowl as shown. Locate circulator bracket perpendicular to cooling coil/dome (*see Fig.*).

Part # A1620

1. Remove present pump and spray tube from the bowl (*if equipped*).
2. Place circulator assembly into pump well with small plate down.

J15 Specifications

Power Cord:	7' with ground connection
Size:	16"W X 18"D X 31" high (41 cm wide X 46 cm long X 79 cm high)
Beverage Bowl & Cover:	Transparent, virtually unbreakable LEXAN® resin
Cabinet:	Stainless steel and white LEXAN® resin
Capacity:	Over 15 US gallons; 57 liters
Refrigeration:	Jet Spray 1/4 h.p. hermetically sealed system
Refrigerant:	Freon 134a non-toxic, oderless
Spray Drive & Fan Motor:	No oiling required
Power Drive Magnet:	Permanent INDOX magnet
Net Weight:	61 lbs (28 kgs)

J15 Wiring Diagram

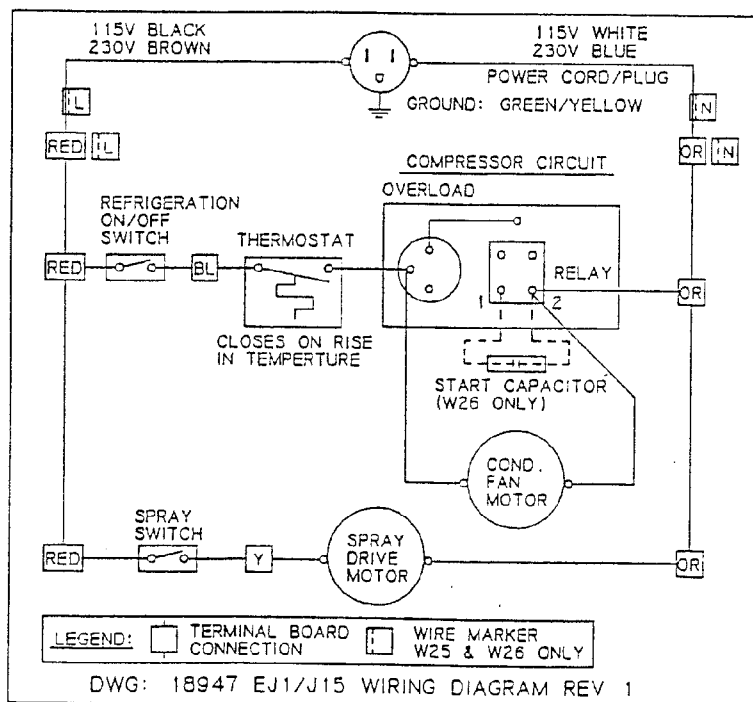

*We reserve the right to make changes in design and/or engineering without notice.
Should the unit require service, take to nearest Jet authorized service center where parts
and service may be obtained (U.S.A. only).*

*UL listing applies for U.S.A. and W-W25 models only.
** C-UL listing applies for Canadian models only.