

# INSTALLATION INSTRUCTIONS

## ED150 "K" STYLE LID KITS,

## P/N 629083204 AND 629083202

These "K" style kits apply to the following ice maker:

**Table 1. Applicable Model**

Ice maker	Width
Manitowoc Q320/420	22"

**Table 2. Loose Shipped Parts**

Item No.	Part No.	Name	Qty.
1	52994	Cover, Gray (629083202)	1
	52934	Cover, Black (629083204)	
2	620027505	DF150 Ice Maker Lid Assembly	1
3	620027306	Bracket	2
4	70217	#8 Screw	6
5	50904	RTV	1
6	91957	Label	1
7	620909401	Installation Instruction	1
8	620701902	Acorn Nut, 8-32 Nylon	2
9	620701901	Sealing Washer	2
10	620042928	Baffle Ice ED150 Adapter Lid	1
11	620701903	#8 Nylon Washer	2

 **WARNING:**

Disconnect power to the unit before installing the adaptor following all lockout/tag out procedures established by the user. Verify all the power is off to the unit before performing any work.

**Failure to comply could result in serious injury, death or damage to the equipment.**

 **WARNING:**

All ice baffle plates and bin states, if included or recommended in this kit, must be installed as directed in this manual or the equipment manufacturer's instructions.

**Failure to comply could result in serious injury, death or damage to the equipment.**

 **WARNING:**

All of the attachment screw and plates must be installed as directed in this manual.

**Failure to comply could result in serious injury, death or damage to the equipment.**

1. Unpack the kit.
2. Insert a baffle assembly into the adapter lid.
3. Place (2) sealing washers (item 9) over studs and (2) flat washers (item 11), then fasten in place with (2) plastic acorn nuts (item 8).
4. Set ice maker lid on the top of the dispenser.
5. Using the slotted holes in the lid as a template, drill four (4) 9/64" diameter holes at the bottom of the slots (see Detail A). **Use extreme care not to drill into the hopper.** Fasten the lid to the dispenser with four (4) #8 sheet metal screws, two on each side.
6. Seal the ice maker to the top of the dispenser as follows:
  - A. Run beads of RTV around the opening in the lid and inside of the perimeter of the ice maker outline so that the ice maker sets on the RTV.
  - B. Set the ice maker onto the lid and position it as required.
  - C. Wipe away the excess RTV.
7. Remove the two rear screws (only) installed in step 5. Use those screws to install the mounting brackets (item 3). Drill 9/64" diameter holes into the ice maker cabinet using the bracket as a template. Use extreme care not to drill into any ice maker components (condenser, tubing, etc.). Secure the brackets using the screws provided.
8. Follow the ice maker manufacturer's instruction to complete the installation of the ice maker including the bin thermostat if so equipped or required.
9. If the plastic acorn nuts interfere with the positioning of the plastic manual fill cover, it may be necessary to make small notches in the back flange of the cover to clear the acorn nuts.

**CAUTION:**

**Bin Thermostat must not interfere with the agitator rotation.**

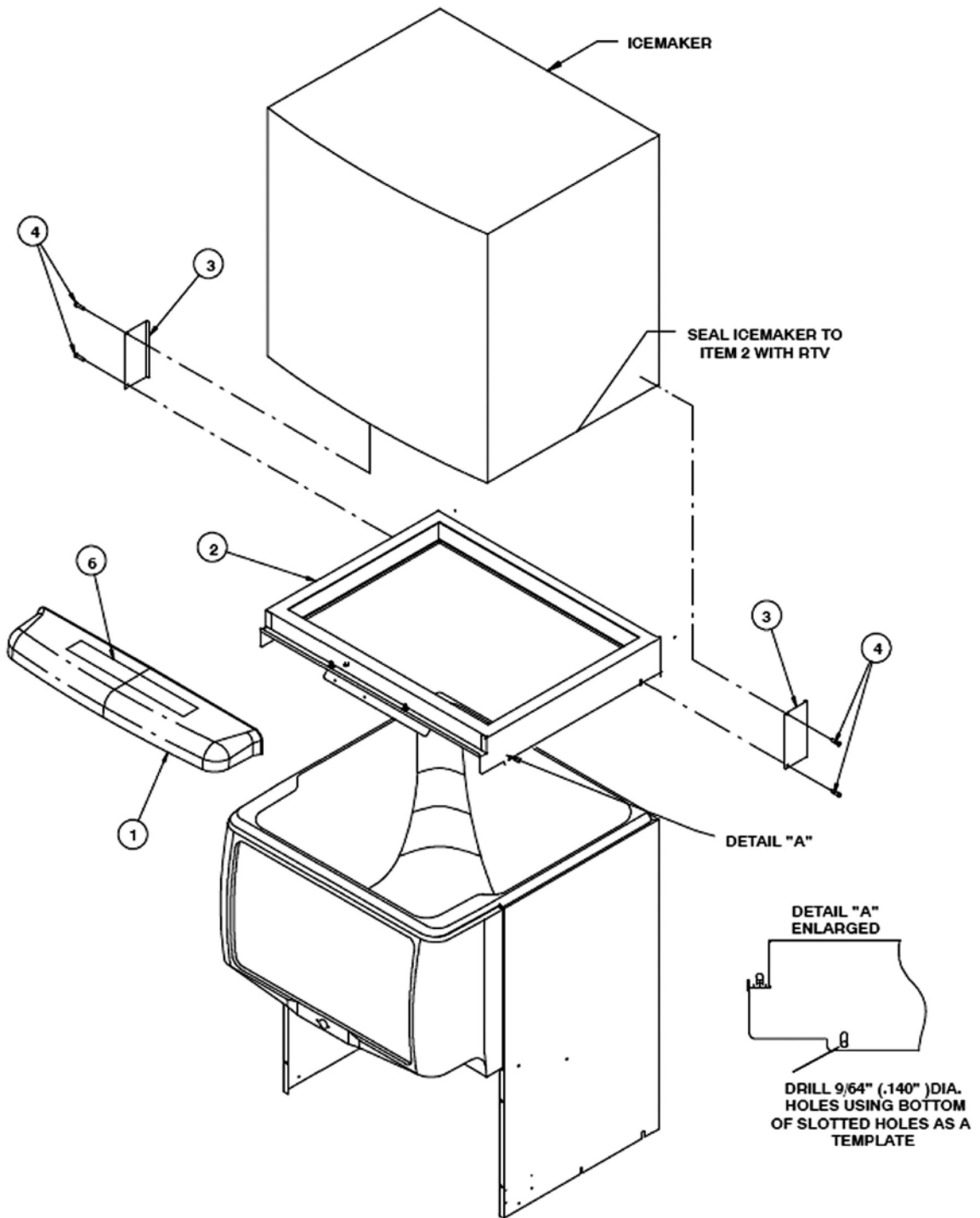

Figure 1. Dispenser Assembly

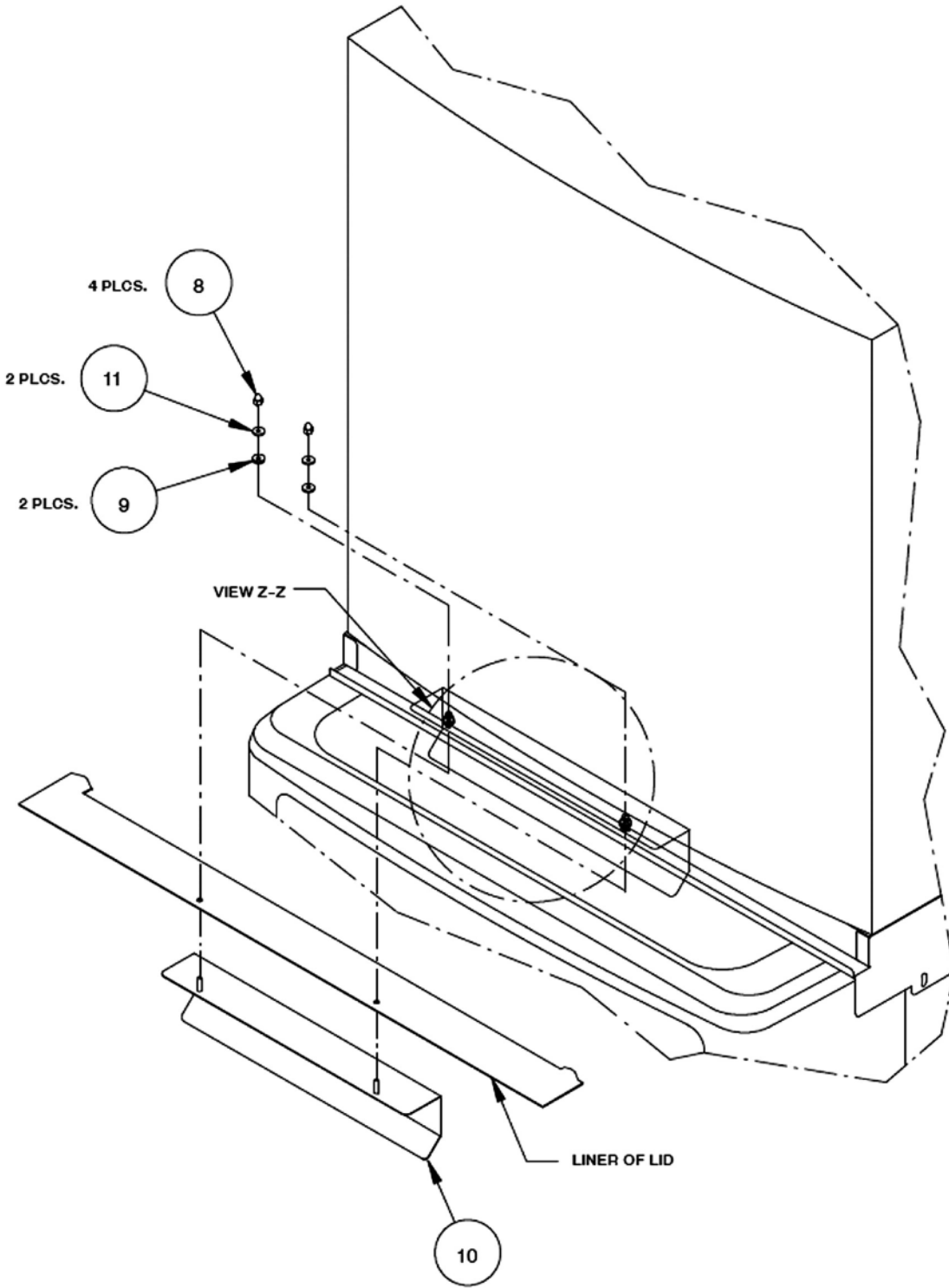
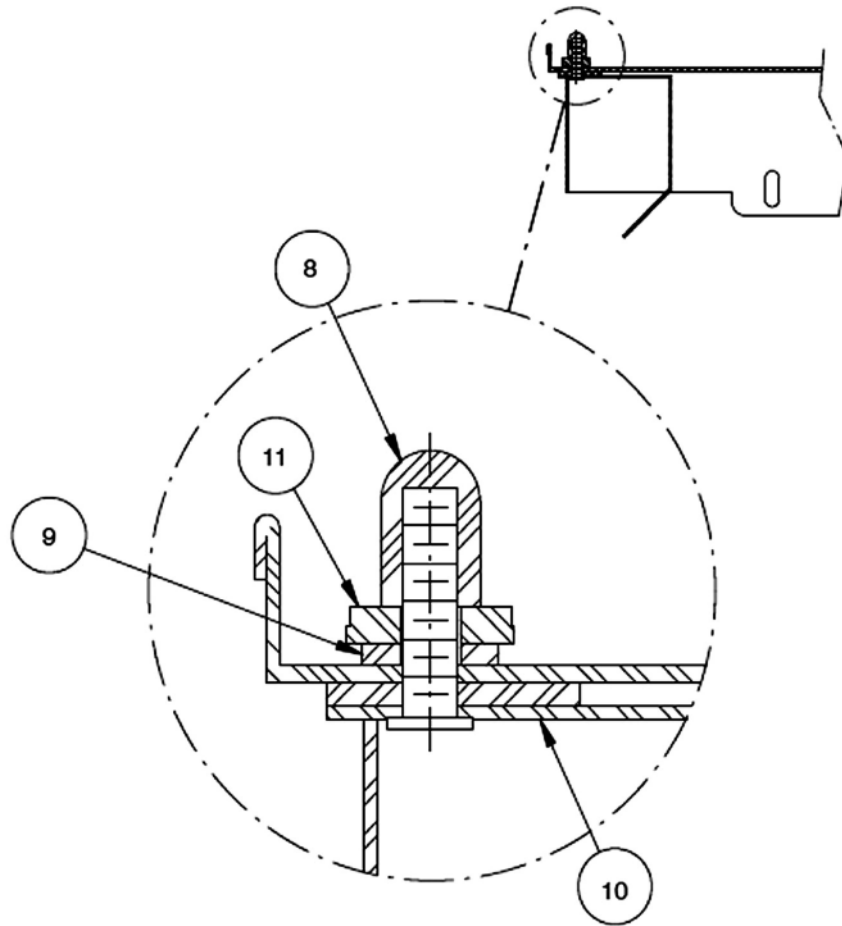

Figure 2. ED150 Kit



**View Z-Z**

**Figure 3. ED150 Kit Detail**