

INSTALLATION INSTRUCTIONS

ED 2xx FlavorBlast™ Kits

SAFETY INSTRUCTIONS

 **WARNING:**

Before starting installation, read and understand all safety label and warnings on the machine. Also review and understand all safety instructions in the owners, installation and service manuals.

Failure to comply could result in serious injury, death or damage to the equipment.

QUALIFIED SERVICE PERSONNEL

 **WARNING:**

Only trained and certified electrical, plumbing and refrigeration technicians should service this unit.

All wiring and plumbing must conform to national and local codes. Failure to comply could result in serious injury, death or equipment damage.

SAFETY PRECAUTIONS

This unit has been specifically designed to provide protection against personal injury. To ensure continued protection observe the following:

 **WARNING:**

Disconnect power to the unit before servicing. Follow all lock out/tag out procedures established by the user. Verify all power is off to the unit before performing any work.

Failure to comply could result in serious injury, death or damage to the equipment.

 **CAUTION:**

Always be sure to keep area around the unit clean and free of clutter.

Failure to keep this area clean may result in injury or equipment damage.

INSTALLATION INSTRUCTIONS:

Loose Shipped Parts

- Drill template
- Sheetmetal housing for Flavor Blast keypad housing
- Sheetmetal bracket to mount white inner nozzle
- 3/16 pop-rivets

Tools Required

- Drill w/ 3/16" drill bit (#10) or equivalent
- Pop rivet gun or equivalent for 3/16 rivets
- Tape measure
- Marker, pen, pencil
- Center punch (not required)
- 1-1/4" hole saw (metal cutting)

Dual Merchandiser Modifications

With the merchandiser removed, measure 15" from either side and mark this with marker, pencil, pen etc. This is center of the merchandiser, see Figure 1. If the merchandiser in this kit already has the holes punched, skip to Step 5.

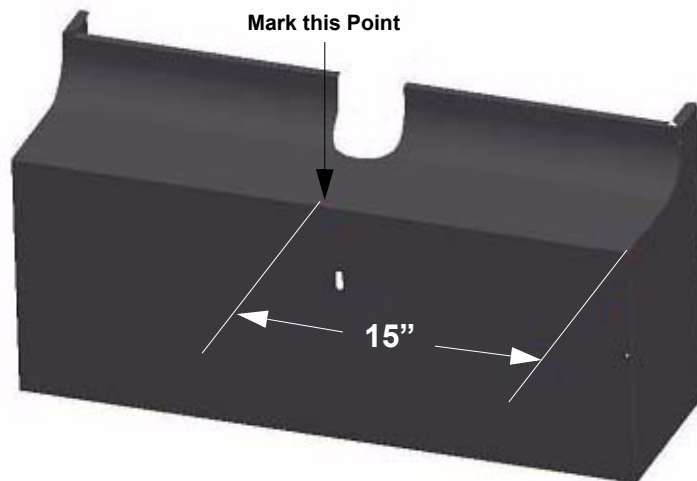

Figure 1.

1. Using the template supplied in the kit, align the template as shown making sure that the center arrow on the template is aligned with the center mark made in Step 1, see Figure 2..

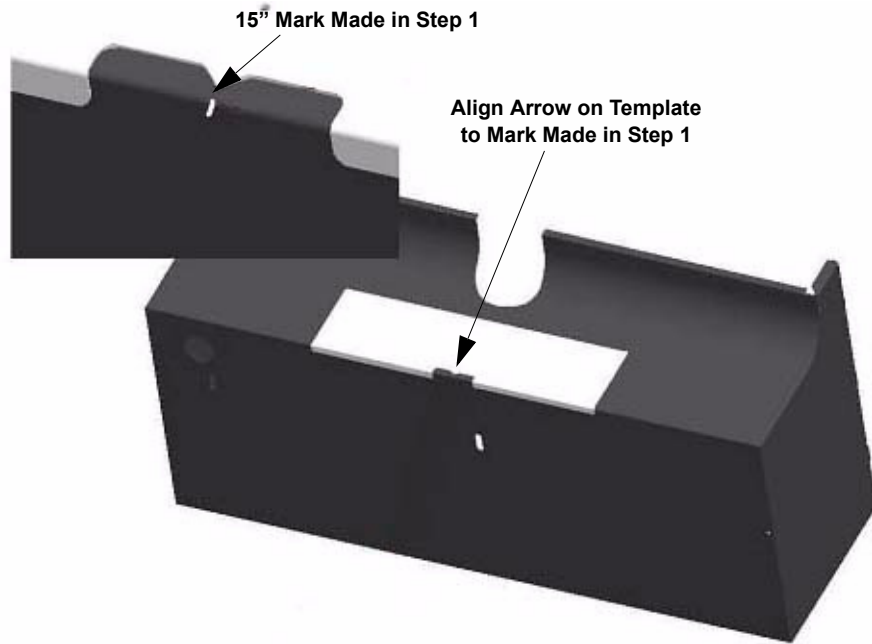

Figure 2.

2. Using the holes in the template, mark all these hole locations with a marker or center punch.
3. Remove template and drill (9) 3/16" holes and (1) 1-1/4" hole, see Figure 3. Be sure to de-burr all the holes.

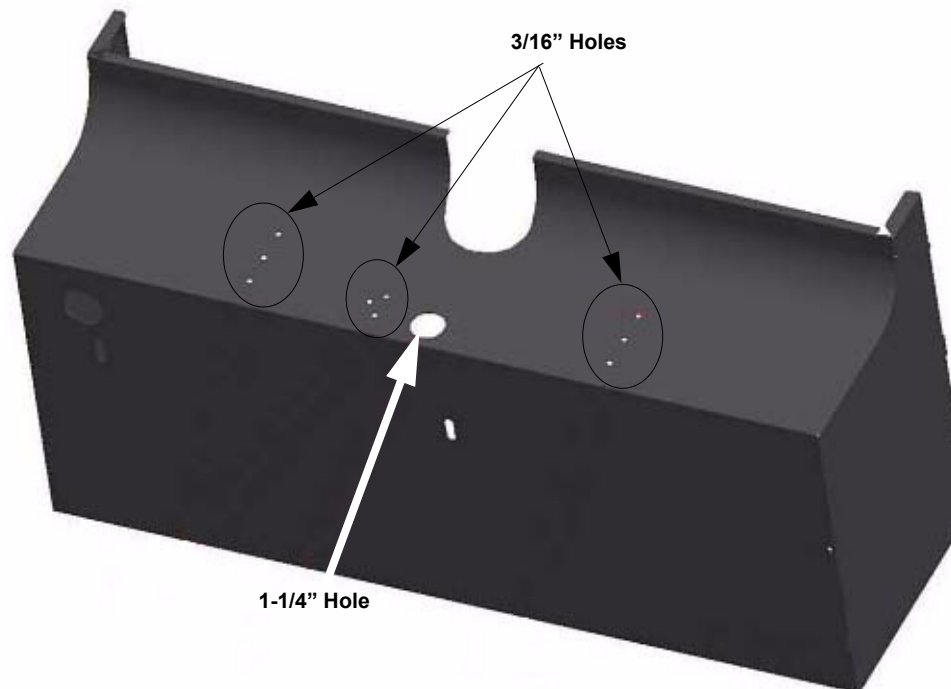

Figure 3.

4. Attach small sheetmetal bracket that mounts the white inner nozzle using 3/16" pop-rivets, see Figure 4. **Make Sure** to install white inner nozzle on bracket before installing.

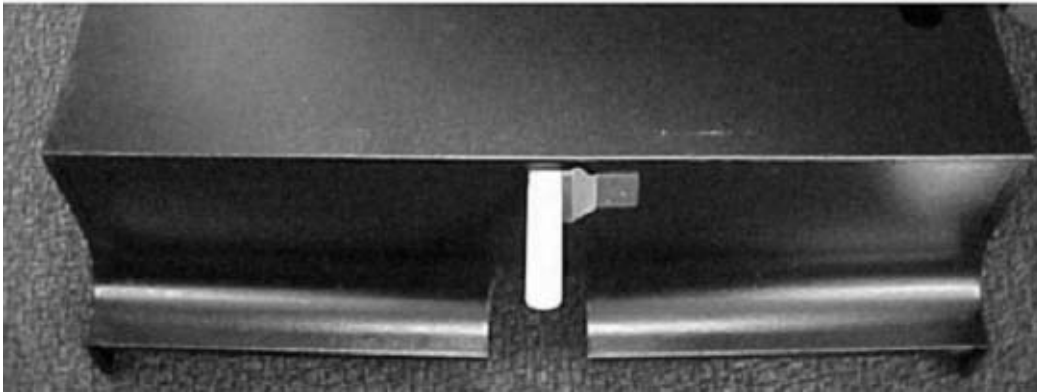

Figure 4.

5. Attach sheetmetal housing for Flavor Blast keypad housing using 3/16" pop-rivets, see Figure 5.



Figure 5.

6. Refer to additional installation manuals included in this kit to finish installation.