

INSTALLATION INSTRUCTIONS

Field Conversion Of An ED300 “Z” Style Unit To A Drip-tray Unit Kit Numbers 629080403 and 629080404

SAFETY INSTRUCTIONS

 **WARNING:**

Before starting installation, read and understand all safety label and warnings on the machine. Also review and understand all safety instructions in the owners, installation and service manuals.

Failure to comply could result in serious injury, death or damage to the equipment.

QUALIFIED SERVICE PERSONNEL

 **WARNING:**

Only trained and certified electrical, plumbing and refrigeration technicians should service this unit.

All wiring and plumbing must conform to national and local codes. Failure to comply could result in serious injury, death or equipment damage.

SAFETY PRECAUTIONS

This unit has been specifically designed to provide protection against personal injury. To ensure continued protection observe the following:

 **WARNING:**

Disconnect power to the unit before servicing. Follow all lock out/tag out procedures established by the user. Verify all power is off to the unit before performing any work.

Failure to comply could result in serious injury, death or damage to the equipment.

 **CAUTION:**

Always be sure to keep area around the unit clean and free of clutter.

Failure to keep this area clean may result in injury or equipment damage.

INSTRUCTIONS

Table 1. Loose Shipped Parts

Item No.	Part No.	Name	Qty.
1	53229	Insulated Drip Tray Assembly – Gray	1
	53230	Insulated Drip Tray Assembly – Black	
2	71038	Cup Rest	1
3	15196	Drip Tray Extension	1
4	10145	Pin – Drip Tray Mounting	3
5	70478R	Clip – Push On	4
6	70750	Hose Clamp	1
7	51774	Tubing, PVC 1” ID	72 IN.
8	629080209	Insulated Lower Panel Assembly – Gray	1
	629080210	Insulated Lower Panel Assembly – Black	
9	71006	Screw – Trph 8–32 x 1–1/8” LG.	2
10	71010	Washer – Captivating #8	2
11	92087	Plumbing Label – Gray	1
	92088	Plumbing Label – Black	
12	92089	Label, Agitator Removal	1
13	92332	Label, Service 800	1
14	91486	Medallion – Cornelius Logo	1
15	50335	Insulation – 1-3/8 ID x 3/8 W Tubing	72 IN.
16	620908801	Installation Instructions	1

⚠ WARNING:

Disconnect power to the unit before servicing. Follow all lock out/tag out procedures established by the user. Verify all power is off to the unit before performing any work.

Failure to comply could result in serious injury, death or damage to the equipment.

⚠ WARNING:

1. Remove lower front panel and discard.

Refer to Figure 1. for cold plate units.

2. Disconnect the “Z” style front cold plate drain assembly by removing the (4) screw type hose clamps from the cold plate black drain elbows. Complete the Z drain removal by loosening the hose clamp that connects the Z drain assembly to the unit drain line.

Refer to Figure 2. for the following Steps.

3. Connect the existing unit drain line to the drip tray drain tube or install a new unit drain line assembly using items 6, 7 and 15. To provide for proper drainage, make sure the drain line runs flat with the bottom of the dispenser and contains no “traps”. Route the unit drain line to an open drain. The drain line must continuously pitch downward to the open drain and contain no traps or improper drainage will result.

⚠ IMPORTANT:

This equipment must be installed with adequate back flow protection to comply with applicable federal, state, and local codes.

4. Mount the drip tray / extension assembly to the unit base with the (3) pins provided in the kit.
5. Install the new lower panel with the (2) 8–32 screws and captivating washers provided.

**CAUTION: DISCONNECT POWER
BEFORE WORKING ON UNIT**

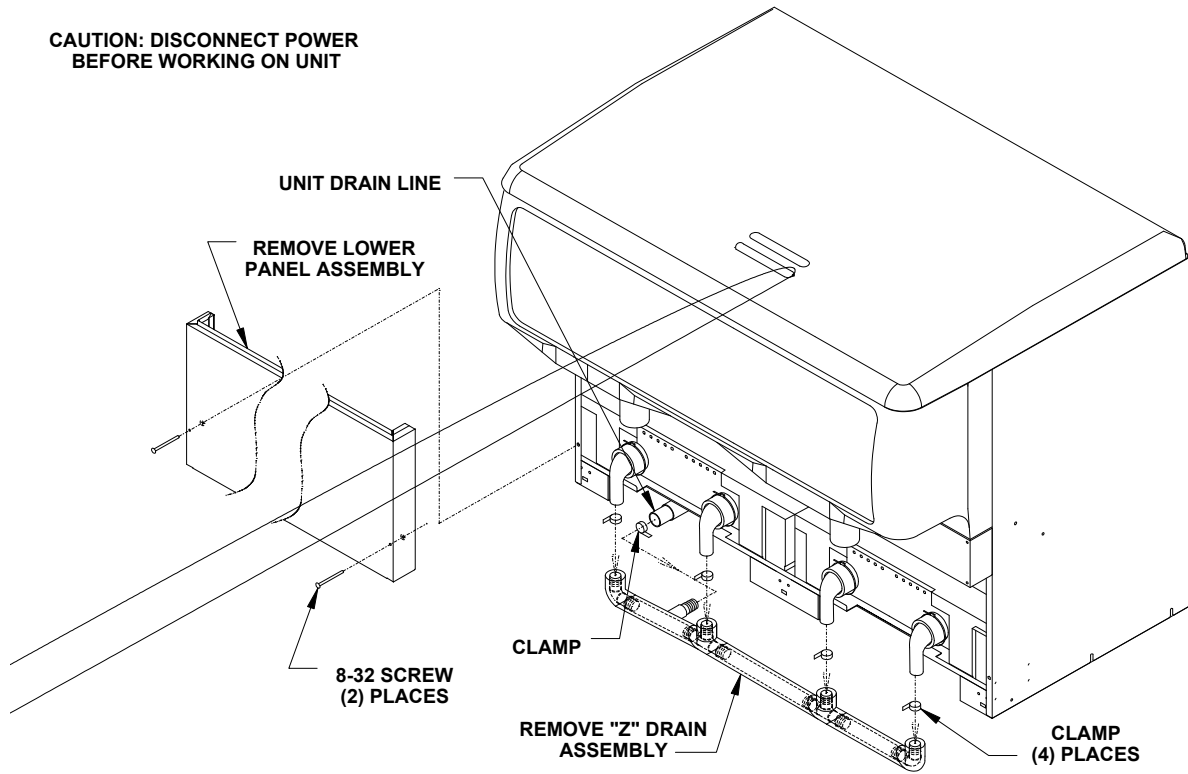

Figure 1.

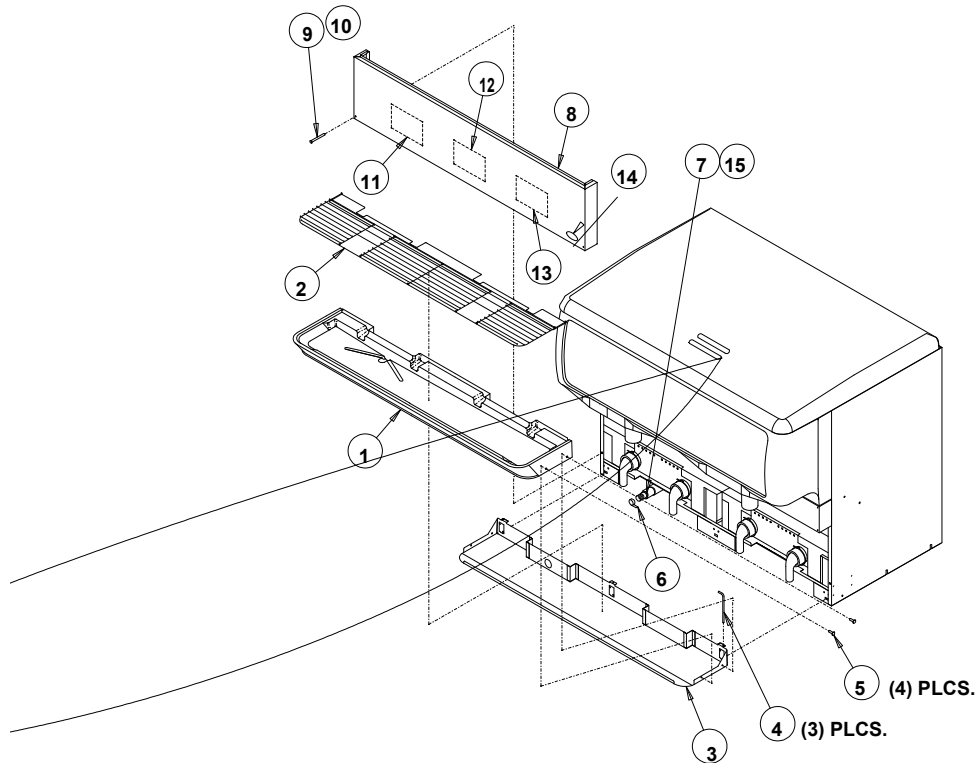

Figure 2.