

INSTALLATION INSTRUCTIONS

ED300 ICEMAKER ADAPTER KIT (P/N 629087957)

This adapter kit is for the following icemaker:

Table 1. Applicable Models

Ice Maker	Width
Ice-O-Matic Ice 1606	44"

Table 2. Parts List

Item No.	Part Number	Description	Qty.
1	620043596	Icemaker Adapter Lid	1
2	620048806	Service Access Cover	1
3	620042919	Ice Baffle ED300	1
4	620051215	Icemaker Mounting Bracket	3
5	70250	1/4-20 x 1/2"	2
6	620701601	#8 X 1/2" Sheetmetal Screw	6
7	620701902	#8-32 Nylon Acorn Nut	4
8	620701901	Sealing Washer	4
9	620701903	#8 Nylon Washer	4
10	50904	RTV 3 oz. Tube	2
11	629087957INS	Installation Instructions	1

 **WARNING:**

Disconnect power to the unit before installing the adaptor following all lockout/tag out procedures established by the user. Verify that all the power is off to the unit before performing any work.

Failure to comply could result in serious injury, death or damage to the equipment.

 **WARNING:**

All ice baffle plates and bin stats, if included or recommended in this kit, must be installed as directed in this manual or the equipment manufacturer's instructions.

Failure to comply could result in serious injury, death or damage to the equipment.

 **WARNING:**

All of the attachment screws and plates must be installed as directed in this manual.

Failure to comply could result in serious injury, death or damage to the equipment.

 **WARNING:**

The dispenser must be secured with 3/8-16 bolts (6) to the counter before installing this Icemaker Adapter Kit. Refer to the installation manual and Figure 2 for the counter mounting template.

Refer to Figure 1 for the following procedure:

1. Remove the plastic ice storage hopper covers (2) that were shipped with the unit.
2. Remove the (2) screws from each side of the dispenser cabinet. Position the icemaker adapter lid on the dispenser and use the (4) cabinet screws to secure the lid to the cabinet.
3. Install the ice baffle (item 4) to the adapter lid as shown in Figure 1.



4. Refer to Figure 1 to locate the icemaker on the adapter lid. The icemaker should extend (over hang) in the rear by 2 inches and centered on the adapter lid. Seal the icemaker base to the adapter lid by running a bead of RTV around the base perimeter on the lid. Set the icemaker onto the RTV. Wipe away any excess RTV.
5. Using the icemaker mounting brackets (item 5) as templates, drill 0.147" diameter holes (drill size 26) into the icemaker cabinet and the adapter lid. **Use caution so as not to drill into any icemaker component (condenser, tubing, ETC.).** Secure the mounting brackets to the icemaker and adapter lid with the #10 sheetmetal screws (item 7) provided in the kit.
6. Follow the icemaker manufacturer's instructions to complete the icemaker installation. **Important: If bin thermostat kit is installed. The thermostat capillary tube and mounting bracket must not interfere with agitator rotation.**
7. Check that the automatic agitation timer located in the dispenser's electrical control box is set for automatic fill cube ice. The control box is located behind the merchandiser. Remove the merchandiser by lifting up on the sides to disengage the mounting "hooks" from the cabinet slots and rotating forward. Refer to the label in the control box for setting agitation times.
8. Install the service access cover (item 2) on the adapter lid (item 1) with the #1/4-20 screws (item 6) provided in the kit. Check for proper operation of the door; it should be free to open by lifting up on the door handle to the left open position.
9. The unit is now ready for operation.

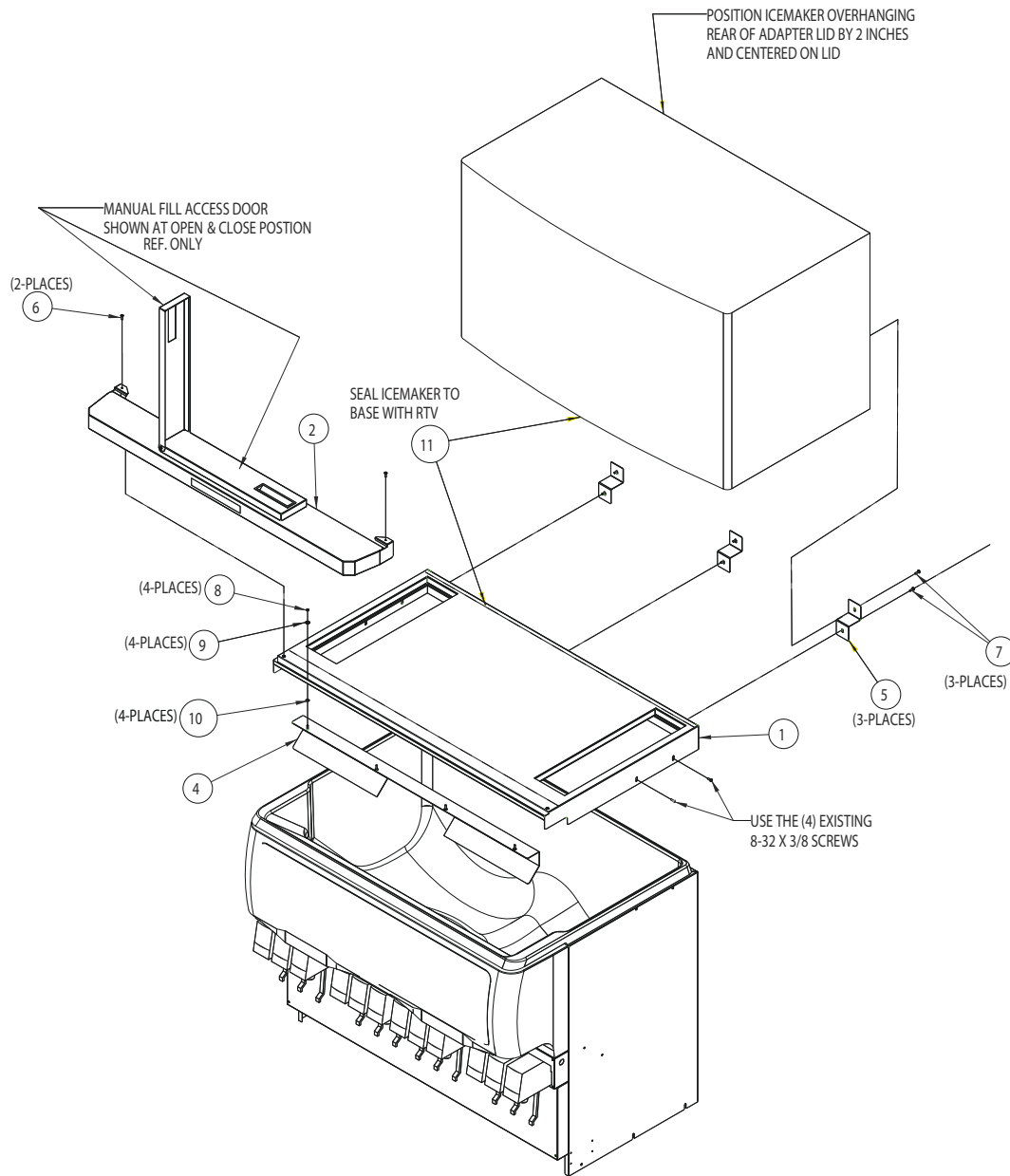
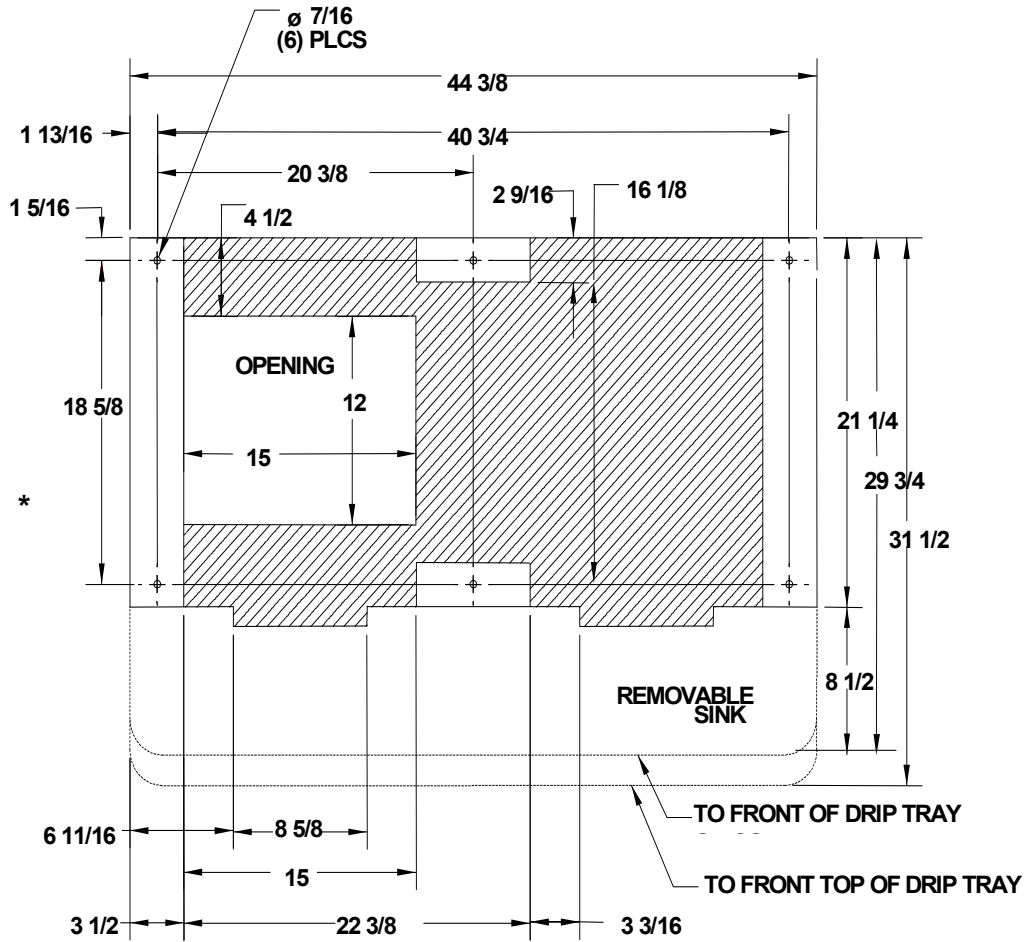

Figure 1. Exploded View of Icemaker Adapter Lid Assembly



NOTE: Recommended counter opening size 12" X 15" for utilities and beverage tubing.

Figure 2. Mounting Template