

INSTALLATION INSTRUCTIONS

FOR ICE MAKER ADAPTER KIT (P/N 629087002) AND (P/N 629087003)

For Hoshizaki Model Series: KM/KML 200/250/400/450/500/600/630/650

Table 1. Applicable Models

Kit Part No.	Dispenser Model
629087002	DF/ED150 - 6 Valve (22 inches wide)
629087003	DF/ED 150 - 8 Valve (24-1/2 inches wide)

Table 2. Loose Shipped Parts

Item No.	Part No.	Name	Qty.
1	620034802	Adapter Lid (629087002 Kit)	1
	620034902	Adapter Lid (629087003 Kit)	1
2	620034808	Manual Ice Fill Cover (629087002 Kit)	1
	620034901	Manual Ice Fill Cover (629087003 Kit)	1
3	22127	Bracket, Ice Maker Mounting	2
4	620701601	Screw, Sheet Metal, No.10 by 1/2-inch Long	12
5	70209	Thumbscrew, No. 8-32 by 3/8-inch Long	1
6	50904	RTV, 3-oz. Tube	1
7	620028305	Bracket, Bin Thermostat	1
8	70164	Screw, Truss-Head, No. 8-32 by 3/4-inch Long	2
9	70100	Nut, Nylok, No. 8-32	2
10	91957	Label, "Disconnect Power Before Cleaning"	1
11	620917305	Installation Instructions	1

⚠ WARNING:

Disconnect power to the unit before installing the adaptor following all lockout/tag out procedures established by the user. Verify that all the power is off to the unit before performing any work.

Failure to comply could result in serious injury, death or damage to the equipment.

⚠ WARNING:

All ice baffle plates and bin stats, if included or recommended in this kit, must be installed as directed in this manual or the equipment manufacturer's instructions.

Failure to comply could result in serious injury, death or damage to the equipment.

⚠ WARNING:

All of the attachment screws and plates must be installed as directed in this manual.

Failure to comply could result in serious injury, death or damage to the equipment.

Perform the following procedure to install the adapter kit.

1. Unpack kit. Make sure all parts in kit are present and in good condition.
2. Position the ice maker adapter lid on the dispenser flush with the rear of the cabinet as shown in Figure 1.
3. Seal ice maker to top of the dispenser adapter lid as follows:
 - A. Locate the ice maker flush with the rear of the lid and centered (for 24-1/2 inches wide dispenser) as shown in Figure 1. Run a bead of RTV on the lid inside the perimeter of the ice maker base outline so that the ice maker will set on the RTV.

- B. Set the ice maker onto the lid. **Note: If installing the ice maker from front of the dispenser, use a length of 3/4-inch diameter or larger PVC pipe as a “roller” to slide the ice maker over the front “drip” flange of the dispenser lid.**
- C. Wipe away any excess RTV.
4. Using the slotted holes in the adapter lid as a template, drill four (4) 0.147” diameter holes (No. 26 drill) into the dispenser cabinet (see Detail A of Figure 1). Use extreme care not to drill into the ice storage bin. Secure the lid to the dispenser with four (4) No. 10 sheet metal screws.
5. Install ice maker mounting brackets two (2) as shown in Figure 1. Using the brackets as templates, drill 0.147” inch diameter holes into the ice maker cabinet and the adapter lid. **Use extreme caution not to drill into any ice maker components (condenser, tubing, etc.).** Secure the brackets to the ice maker cabinet with the No. 10 sheet metal screws provided in the kit.
6. Follow the ice makers Manufacturer’s instructions to complete installation of the ice maker
7. **IMPORTANT: The bin thermostat bracket (item 7) must be installed (see Figure 2) in order to prevent overfilling the ice storage bin**
 - A. Remove the ice maker front panel.
 - B. Locate the bin thermostat on the lower-right side wall of the ice drop area and remove the two (2) thumbscrews that hold the bin thermostat in place.
 - C. Mount the bin thermostat to the bracket (item 7) provided with the kit as shown in Figure 2.
 - D. Using the thumbscrews from step B preceding, secure the “kit” bracket/bin thermostat assembly from step C preceding to the same ice drop area position. The purpose of this “kit” bracket is to lower the bin thermostat for proper filling of the ice storage bin.
 - E. Replace the ice maker front panel.
8. Install the caution label (item 10) on the manual fill cover (item 2) and secure the cover to the adapter lid with the No. 8-32 thumbscrew.
9. The ice maker/dispenser is ready for operation.

 **CAUTION:**
Bin Thermostat must not interfere with the agitator rotation.

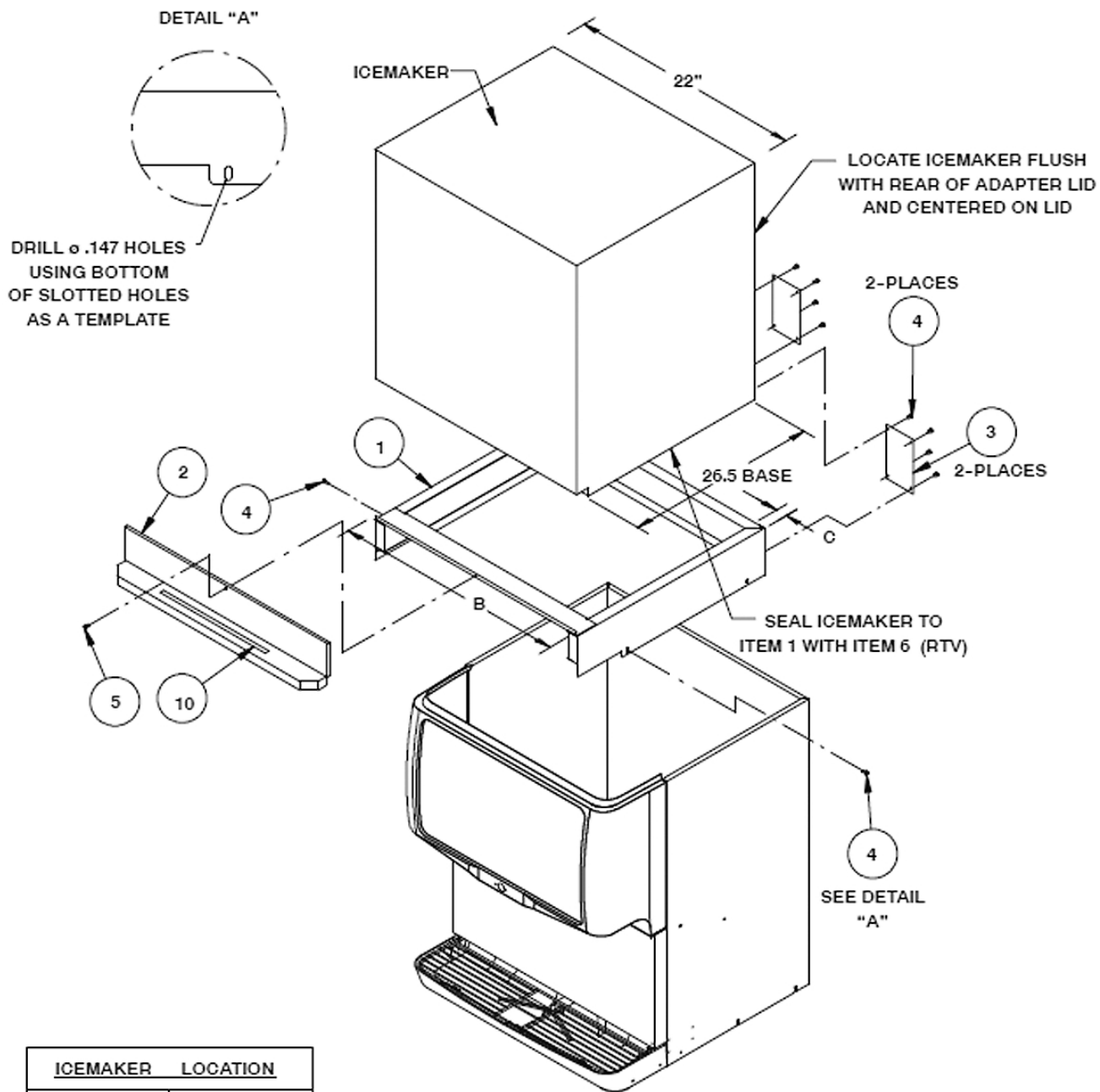

ICE MAKER	LOCATION
LID "B" DIM	DIM C
22 IN.	FLUSH W/ SIDES OF LID
24-5/8 IN.	1-5/16 IN.

Figure 1.

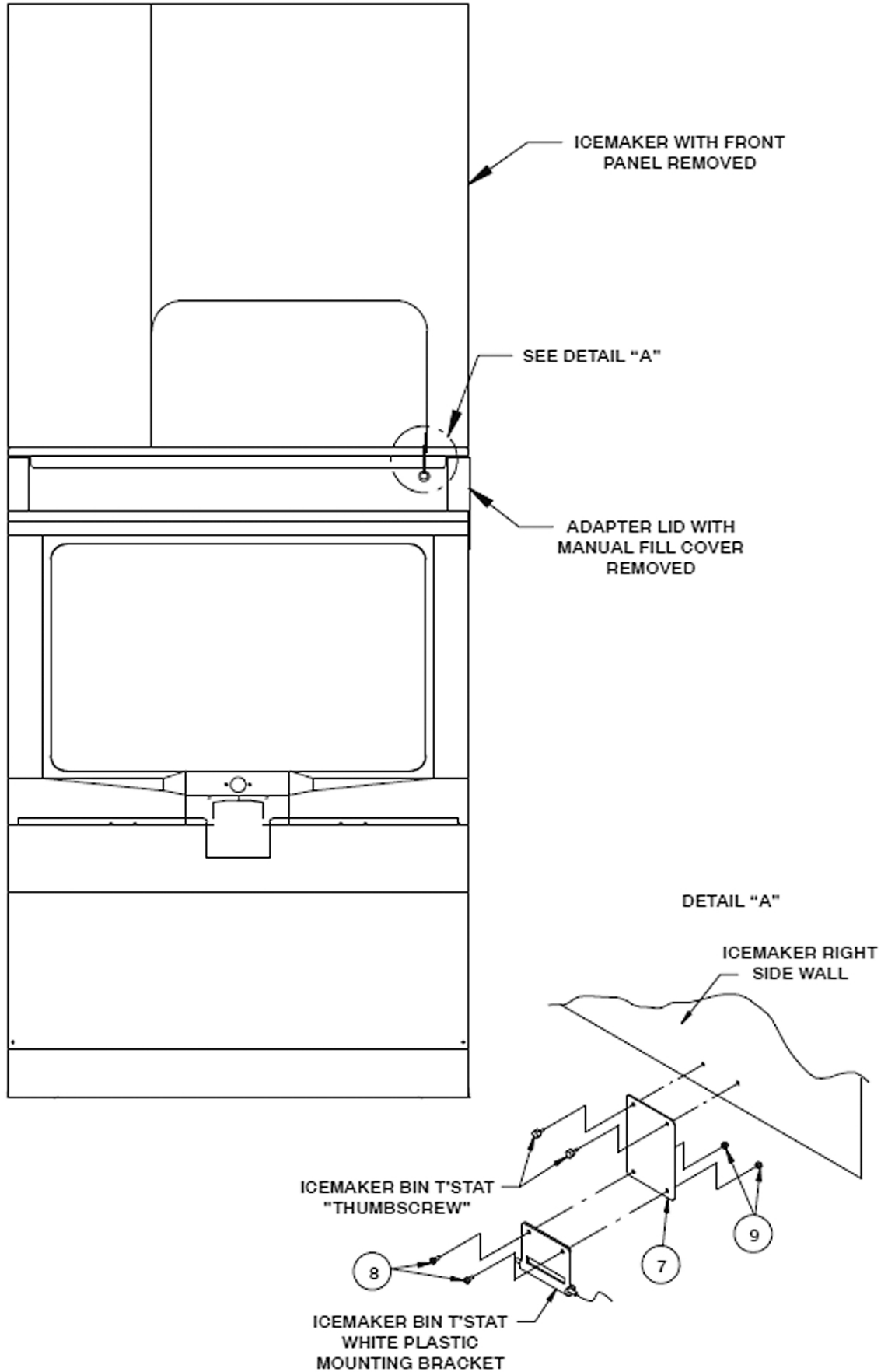

Figure 2.