

# INSTALLATION INSTRUCTIONS

## "K" STYLE LID KIT, P/N 630000085

These "K" style kits apply to the following ice makers and are for use with ED/DF 150 dispensers:

**Table 1. Applicable Models**

Ice Maker	Size
Wilshire WCC500/700	14 1/2" Wide

**Table 2. Loose Shipped Parts**

Item No.	Part No.	Name	Qty.
1	620030602	Lid Assembly,	1
2	15303	Bracket	1
3	50904	RTV, Clear, 732, 3 oz. Tube	1
4	70217	#8 Sheet Metal Screw	6
5	91957	Label, <i>Disconnect Before Cleaning</i>	1
6	70188	Thumb Screw #8-32 X 1/2"	1
7	620911301	Installation Instruction	1
8	22127	Bracket, Mounting	1
9	620030601	Cover, RH Assembly	1



**WARNING:**

Disconnect power to the unit before installing the adaptor following all lockout/tag out procedures established by the user. Verify that all the power is off to the unit before performing any work.

**Failure to comply could result in serious injury, death or damage to the equipment.**



**WARNING:**

All ice baffle plates and bin stats, if included or recommended in this kit, must be installed as directed in this manual or the equipment manufacturer's instructions.

**Failure to comply could result in serious injury, death or damage to the equipment.**



**WARNING:**

All of the attachment screws and plates must be installed as directed in this manual.

**Failure to comply could result in serious injury, death or damage to the equipment.**

1. Set Ice maker lid on the top of the dispenser and position it flush with the back and sides of the dispenser.
2. Using the slotted holes in the lid as a template, drill four (4) 0.140" diameter holes at the bottom of the slots (see Detail A). Use extreme care not to drill into the hopper. Fasten the lid to the dispenser with four (4) #8 sheet metal screws, two on each side.
3. Seal the ice maker to the top of the dispenser as follows: (Flush with rear and left side)
  - A. Apply beads of RTV around the opening in the lid and inside the perimeter of the ice maker outline so that the ice maker sets on the RTV.
  - B. Set the ice maker onto the lid and position it as required.
  - C. Wipe away any excess RTV.
4. Remove the left rear screw (only) installed in Step 2. Use that screw to install the mounting bracket (item 2) and install the cover (item 9) to the rear of the dispenser and the ice maker. Drill 9/64" diameter holes into the ice maker cabinet using the bracket as a template. **Use extreme caution not to drill into any ice maker components (condenser, tubing, etc.).** Secure the brackets using the screws provided.

5. Follow the ice maker manufacturers instruction to complete the installation of the ice maker including the bin thermostat, if so equipped or required.

**CAUTION:**  
Bin thermostat must not interfere with agitator rotation.

6. Place the lid (item 4) in position over the stainless steel flange and install the thumb screw (item 7).

**CAUTION:**  
The back of the ice maker must be flush with the back of the lid (item 1).

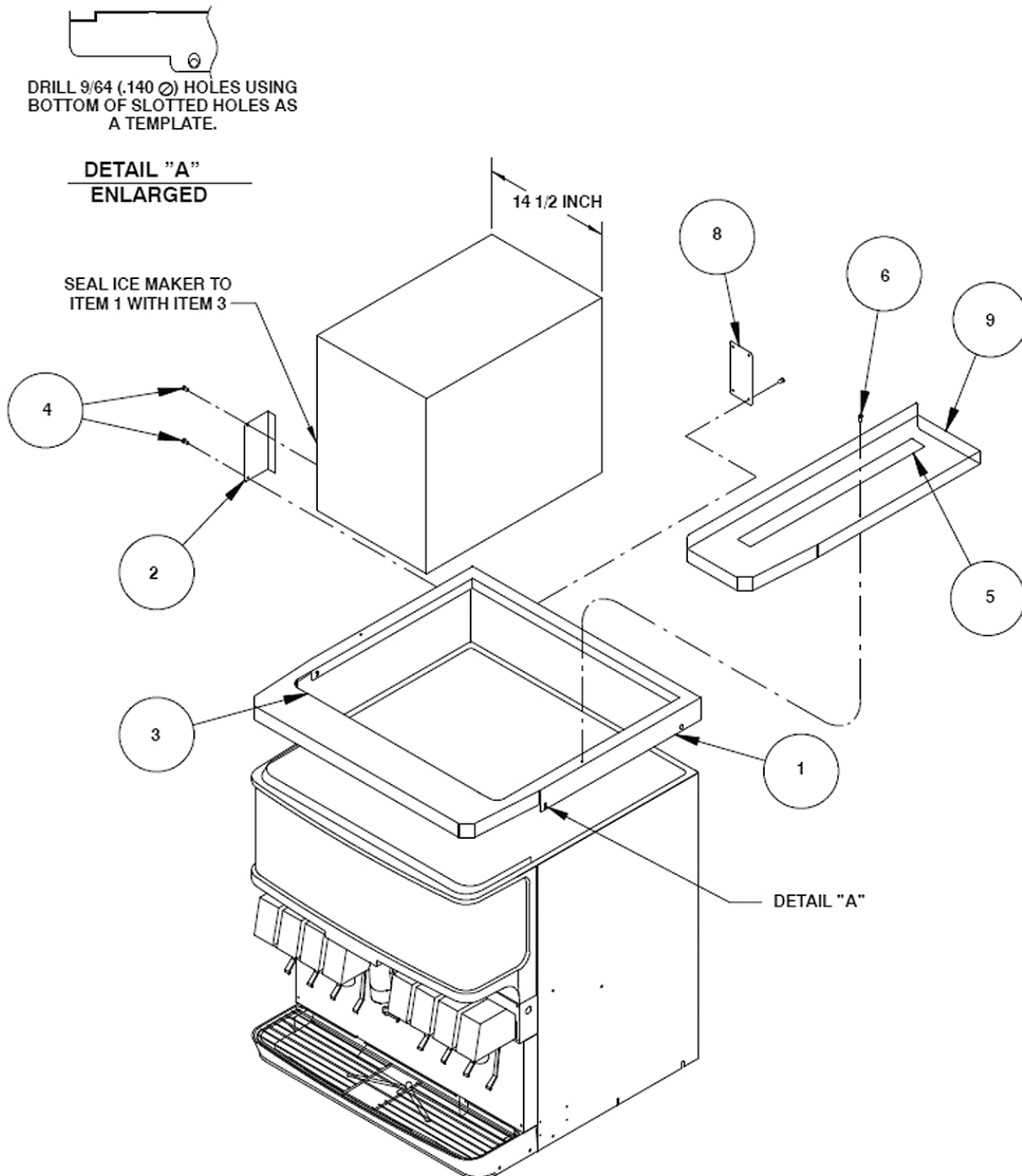

Figure 1.