

INSTALLATION INSTRUCTIONS

FOR ED/DF 150-8 “K” STYLE LID KITS, P/N 629087910 AND 629087911

These “K” style kits apply to the following ice makers:

Table 1

| Ice Maker | Width |
|-------------------------|-------|
| Manitowoc Q320 and Q420 | 22” |

Table 2

| Table 1. Loose-Shipped Parts | | | |
|------------------------------|-----------|----------------------------|------|
| Item No. | Part No. | Name | Qty. |
| 1 | 620043511 | Cover, Gray (629087911) | 1 |
| | 620043512 | Cover, Black – (629087910) | 1 |
| 2 | 620046012 | Lid Assembly | 1 |
| 3 | 22127 | Bracket | 2 |
| 4 | 70217 | #8 Screw | 6 |
| 5 | 50904 | RTV | 1 |
| 6 | 90221 | Label | 1 |
| 7 | 620919518 | Installation Instruction | 1 |
| 8 | 620701902 | Acorn Nut, 8-32 Nylon | 2 |
| 9 | 620701901 | Sealing Washer | 2 |
| 10 | 620037007 | Ice Baffle ED2XX | 1 |
| 11 | 620701903 | #8 Nylon Washer | 2 |

⚠ WARNING:

Disconnect power to the unit before installing the adaptor following all lockout/tag out procedures established by the user. Verify that all the power is off to the unit before performing any work.

Failure to comply could result in serious injury, death or damage to the equipment.

⚠ WARNING:

All ice baffle plates and bin stats, if included or recommended in this kit, must be installed as directed in this manual or the equipment manufacturer’s instructions.

Failure to comply could result in serious injury, death or damage to the equipment.

⚠ WARNING:

All of the attachment screws and plates must be installed as directed in this manual.

Failure to comply could result in serious injury, death or damage to the equipment.

Perform the following procedure to install the adapter kit.

1. Unpack and inspect the kit.
2. Insert baffle assembly into the adapter lid.
3. Place (2) sealing washers (item 9) over studs and (2) flat washers (item 11), then fasten in place with (2) plastic acorn nuts (item 8).
4. Set ice maker lid on the top of the dispenser.



5. Using the slotted holes in the lid as a template, drill four (4) 0.140" diameter (9/64") holes at the bottom of the slots (see Detail A). **Use extreme care not to drill into the hopper.** Fasten the lid to the dispenser with four (4) #8 sheet metal screws, two on each side.
6. Seal the ice maker to the top of the dispenser as follows:
 - A. Run beads of RTV around the opening in the lid and inside of the perimeter of the ice maker outline so that the ice maker sets on the RTV.
 - B. Set the ice maker onto the lid and position it as required.
 - C. Wipe away the excess RTV.
7. Drill 9/64" diameter holes into the ice maker cabinet using the bracket as a template. **Use extreme care not to drill into any ice maker components (condenser, tubing, etc.).** Secure the brackets using the screws provided.
8. Follow the ice maker manufacturers instructions to complete the installation of the ice maker, including the bin thermostat if so equipped or required.
9. If the plastic acorn nuts interfere with the positioning of the plastic manual fill cover, it may be necessary to make small notches in the back flange of the cover to clear the acorn nuts.

NOTE: Bin thermostat must not interfere with the agitator rotation.

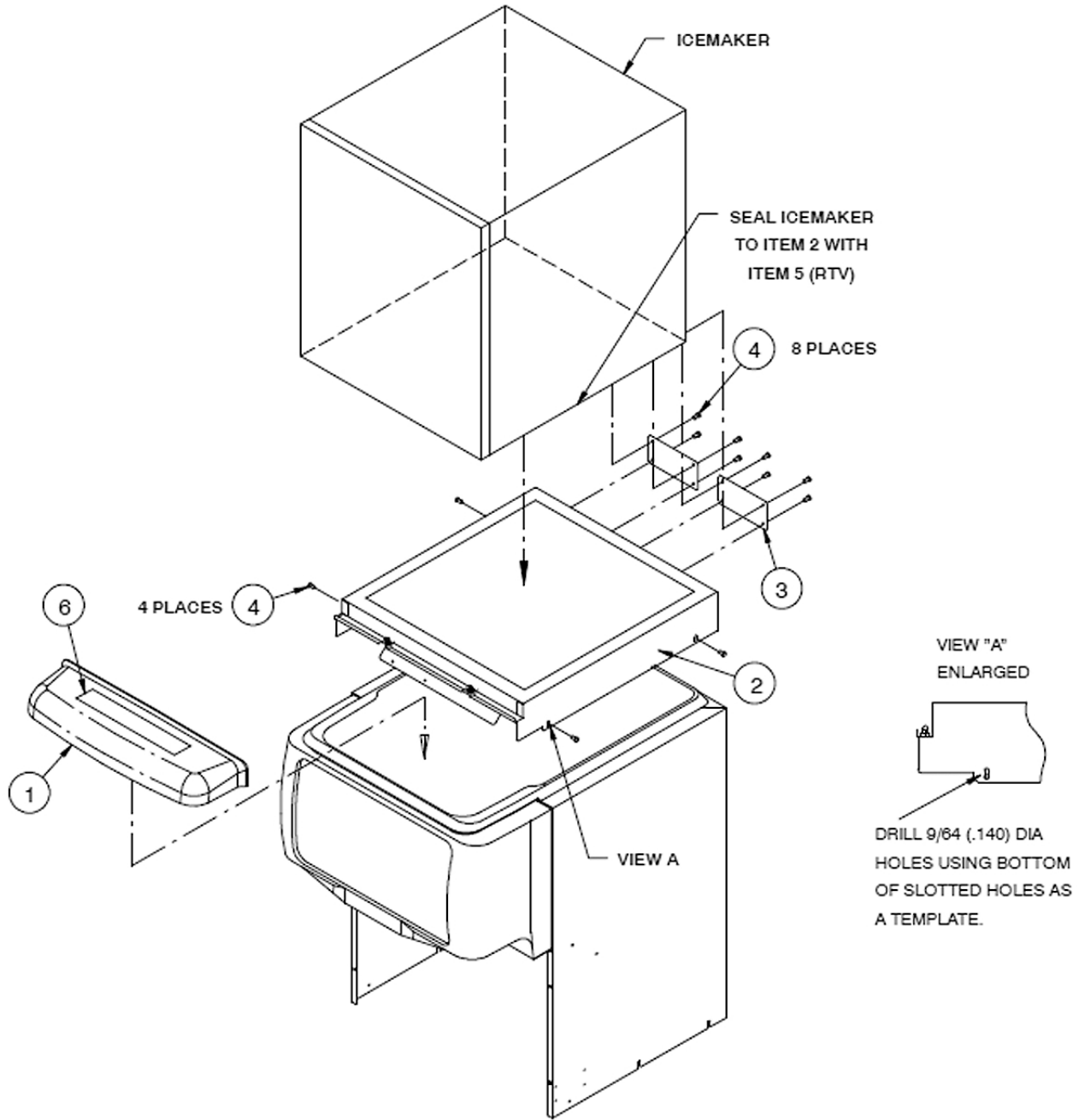

Figure 1. ED/DF 150-8

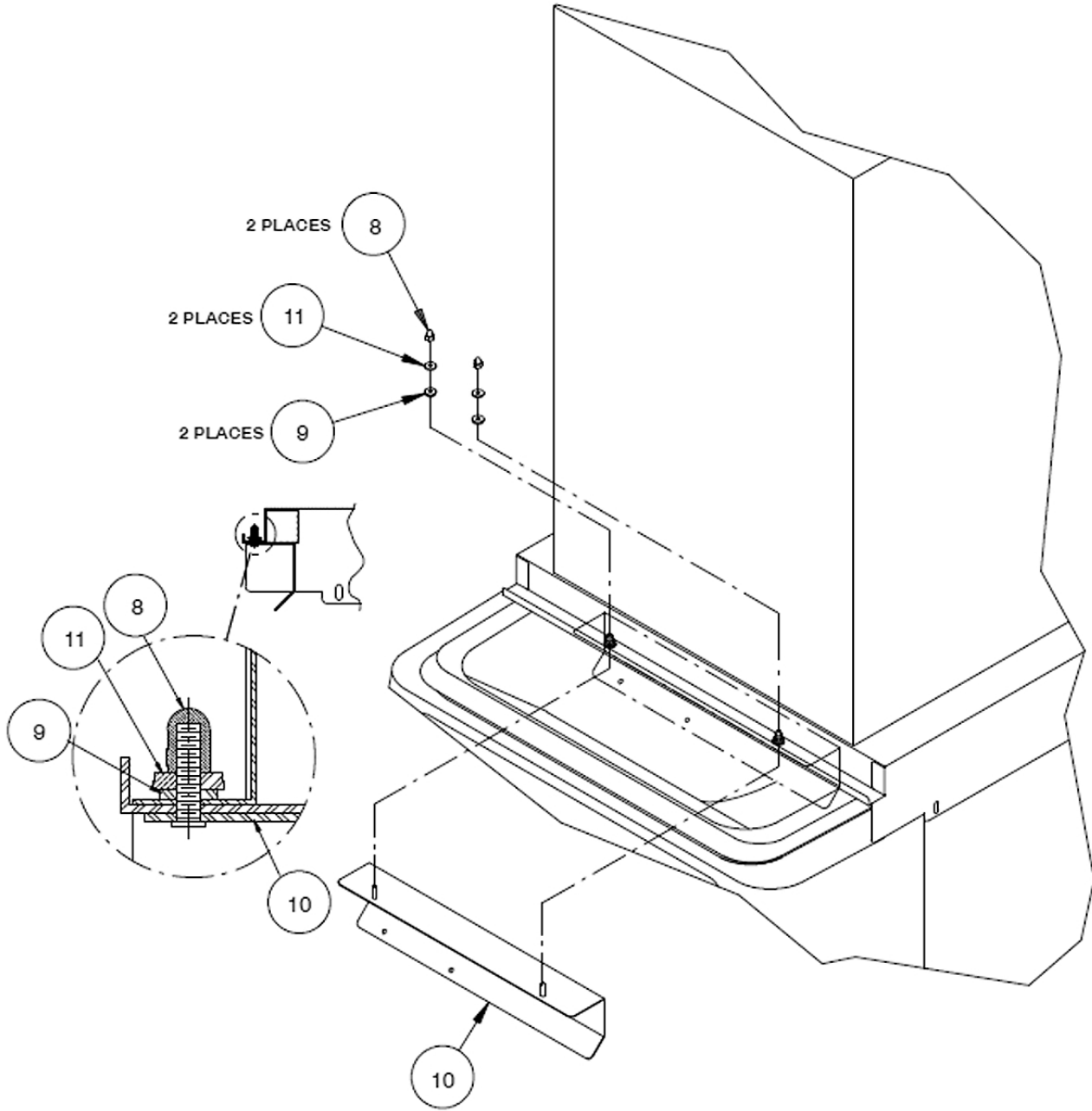

Figure 2. ED/DF 150-8