

INSTALLATION INSTRUCTIONS FOR KIT 629084601 ICE DIVERTER ED/DF300 DISPENSERS

NOTE: For dispensing Scotsman NM650 “Nugget” style ice and Wilshire MCC500 and MCC700 “Chunklet” style ice cubes.



WARNING:

Disconnect power to the unit before servicing. Follow all lock out/tag out procedures established by the user. Verify all power is off to the unit before performing any work.

Failure to comply could result in serious injury, death or damage to the equipment.

1. Remove upper front panel/merchandiser from dispenser.
2. Remove ice chute and discard gate restrictor.
3. Install ice diverter as shown.
4. Reinstall front panel and reconnect power to unit.
5. Set agitation timer to minimum motor ON time (0.5 Sec.) and maximum OFF time (3 hours).

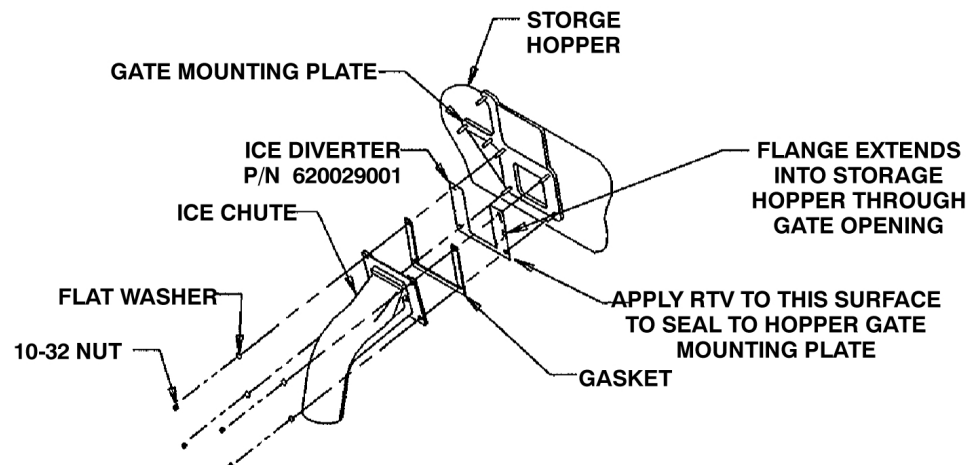

LEFT SIDE ICE CHUTE

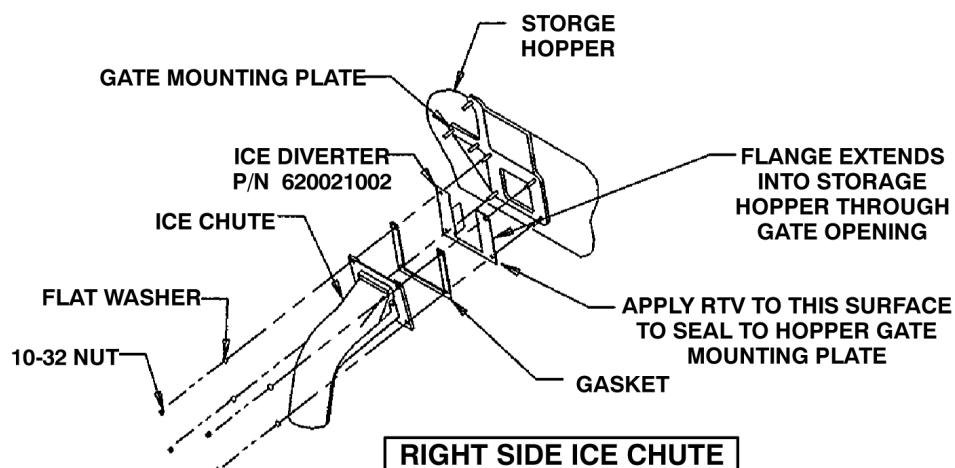

RIGHT SIDE ICE CHUTE