

INSTALLATION INSTRUCTIONS

FOR

ED/DF300 30" CMM1530 NORDIC SS STYLE LID KIT

SAFETY

 **WARNING:**

Before starting installation, read and understand all safety label and warnings on the machine. Also review and understand all safety instructions in the owners, installation and service manuals.

Failure to comply could result in serious injury, death or damage to the equipment.

QUALIFIED SERVICE PERSONNEL

 **WARNING:**

Only trained and certified electrical, plumbing and refrigeration technicians should service this unit.

All wiring and plumbing must conform to national and local codes. Failure to comply could result in serious injury, death or equipment damage.

SAFETY PRECAUTIONS

This unit has been specifically designed to provide protection against personal injury. To ensure continued protection observe the following:

 **WARNING:**

Disconnect power to the unit before servicing. Follow all lock out/tag out procedures established by the user. Verify all power is off to the unit before performing any work.

Failure to comply could result in serious injury, death or damage to the equipment.

 **CAUTION:**

Always be sure to keep area around the unit clean and free of clutter. Failure to keep this area clean may result in injury or equipment damage.

 **WARNING:**

All ice baffle plates and bin starts, if included or recommended in this kit, must be installed as directed in this manual or the equipment manufacturer's instructions.

Failure to comply could result in serious injury, death or damage to the equipment.

 **WARNING:**

All of the attachment screws and plates must be installed as directed in this manual.

Failure to comply could result in serious injury, death or damage to the equipment.

 **WARNING:**

The dispenser must be secured with 3/8 X16 bolts (6) to the counter before installing the ice maker adapter kit. Refer to the installation manual for the counter mounting template.

This Nordic style kit applies to the Cornelius 30" Wide CCM1530 Nordic Ice Maker.

Table 1: Loose Shipped Parts

Item No.	Part No.	Name	Qty.
1	620046139	Ice Maker Adapter Lid	1
2	620050521	Manual Fill Cover	1
3	620051215	Ice Maker Mounting Bracket	2
5	50904	RTV Sealant 3oz. Tube	1
6	602701601	#10 X 1/2" Sheet Metal Screw	8
7	620204719INS	Installation Instructions	1
8	630500109	Bin Stat	1

1. Position the ice maker adapter lid (item 1), flush with the rear of the cabinet, on the dispenser.
2. Seal the ice maker base to the adapter lid as follows:
 - A. Locate the ice maker two inches from the rear and flush with the sides of the lid. Run a bead of RTV inside the perimeter of the ice maker base so that the base sets on the RTV.
 - B. Set the ice maker onto the lid. Note: if installing the ice maker from the front of the dispenser, use a piece of 1" PVC pipe or larger as a "roller" to slide the ice maker over the front mounting bracket of the manual fill cover.
 - C. Wipe away any excess RTV.
3. With the ice maker installed on top of the adapter lid, drill 0.147 diameter holes (#26 drill) into the dispenser cabinet using the slotted holes in the side flanges of the lid as templates. Be careful not to drill into the ice storage hopper. Use of a drill stop (1/4 in.) is recommended. Secure the lid to the cabinet with (4) #10 sheet metal screws (item 6).
4. Drill 0.147 diameter holes into the ice maker cabinet and adapter lid using the ice maker mounting brackets (item 3) as templates. Be careful not to drill into any ice maker component (condenser, tubing, etc.). Secure the mounting brackets to the ice maker and adapter lid with the #10 sheet metal screws (item 6) provided in the kit.
5. Install the wire form bracket supplied with the bin stat kit (item 4), through the 5/8" diameter hole in the bottom of the ice maker. Wrap the eye of the wire form over the stud near the hole to the end of the wire form bracket and wrap the tube around the end of the bracket several times, ensuring the tube is secure.

NOTE: The bin stat must not interfere with the agitator rotation or be in the path of ice falling from the ice maker. If it interferes with the agitator or is in the path of the ice, bend the bracket out of the way.
6. Check that the automatic agitation timer, located in the dispenser's electrical control box, is set for automatic fill cube ice. The control box is located behind the merchandiser. Remove the merchandiser by lifting up on the sides to disengage the mounting "hooks" from the cabinet slots and rotate it forward.
7. Refer to the label in the control box for setting agitation times.
8. Install the manual fill cover (item 2) on the adapter lid (item 1). Insert the hinge pins into the pivot brackets on the adapter lid with the cover open. Check that cover opens and closes correctly.
9. The unit is now ready for operation.

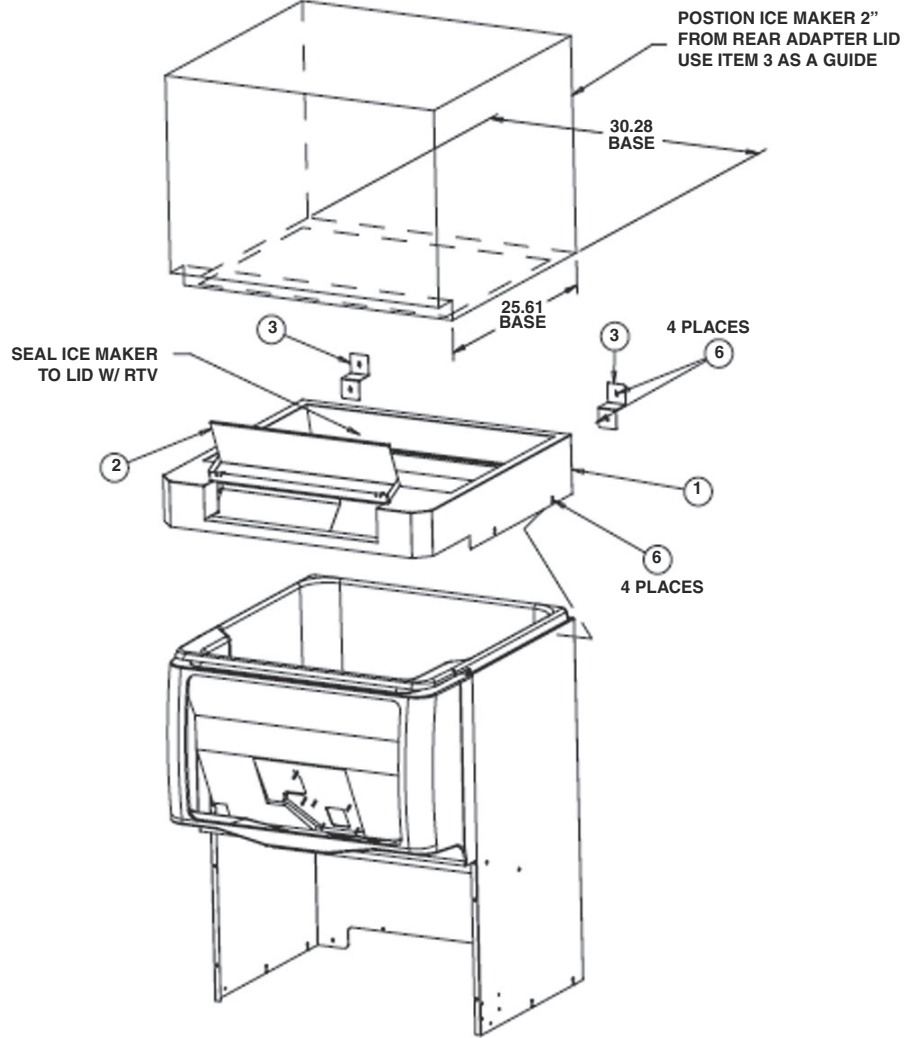

Figure 1.

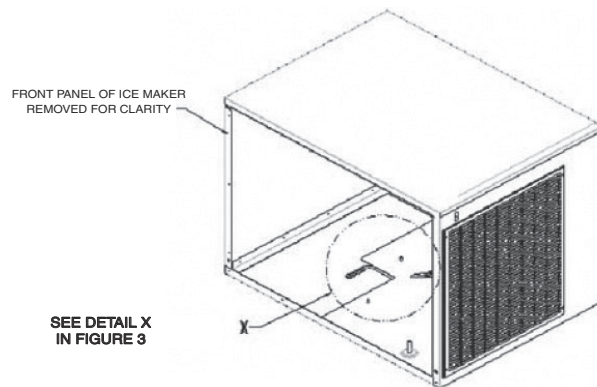

Figure 2.

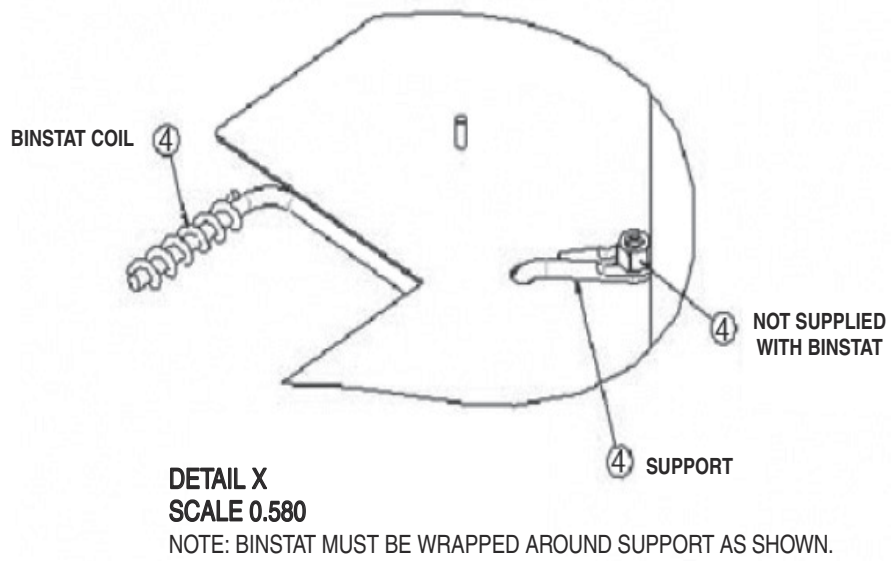

Figure 3.