

INSTALLATION INSTRUCTIONS

ED2XX-B Conversion from Drip Tray to “Z” Style or “Z” Style to Drip Tray

SAFETY INSTRUCTIONS

 **WARNING:**

Before starting installation, read and understand all safety label and warnings on the machine. Also review and understand all safety instructions in the owners, installation and service manuals.

Failure to comply could result in serious injury, death or damage to the equipment.

QUALIFIED SERVICE PERSONNEL

 **WARNING:**

Only trained and certified electrical, plumbing and refrigeration technicians should service this unit.

All wiring and plumbing must conform to national and local codes. Failure to comply could result in serious injury, death or equipment damage.

SAFETY PRECAUTIONS

This unit has been specifically designed to provide protection against personal injury. To ensure continued protection observe the following:

 **WARNING:**

Disconnect power to the unit before servicing. Follow all lock out/tag out procedures established by the user. Verify all power is off to the unit before performing any work.

Failure to comply could result in serious injury, death or damage to the equipment.

 **CAUTION:**

Always be sure to keep area around the unit clean and free of clutter.

Failure to keep this area clean may result in injury or equipment damage.

INSTRUCTIONS

Refer to Figure 1. and Figure 2. for the following procedures:

Conversion from Drip Tray to “Z” Style

 **WARNING:**

Disconnect power to the unit before servicing. Follow all lock out/tag out procedures established by the user. Verify all power is off to the unit before performing any work.

Failure to comply could result in serious injury, death or damage to the equipment.

1. Remove the lower front panel (2 screws) and discard.
2. Remove the (2) drip tray mounting pins, located at the lower left and right hand corners of the unit base, by lifting up on the pins to disengage the drip tray assembly from the base.
3. Pull the drip tray assembly forward from the unit base to provide access to remove the hose clamp on the drip tray drain line located at the rear of the drip tray. Remove both the drip tray and the drain line and discard.
4. Assemble the “Z” style lower panel to the unit with the (2) No. 8-32 X 2–1/4 inches long screws and retaining washers provided with this kit.
5. The unit is now ready for operation.

Conversion from “Z” Style to Drip Tray

1. Remove the lower front panel (2 screws) and discard.
2. Determine the length of the drip tray drain line required to “reach” an open drain. It is important that the drain line pitch continuously downward from the drip tray and contains no “traps” for proper drainage. The drain line must be installed with adequate back flow protection to comply with Federal, State, and local codes. Cut the drain line and insulation as required to comply with code for this installation.
3. Refer to Figure 2. for installing the coupling and adapter fittings provided in the kit to the drip tray drain fitting.
4. Install the drip tray into the extension with (4) push-on clips. Secure the insulated drain line to the drip tray barb adapter from step No. 3 with the hose clamp provided in the kit.
5. Secure the drip tray assembly from step No. 4 to the unit base with (2) pins. Note that the rear of the extension has two tabs that fit into rectangular openings in the base for engagement of the pins.
6. Assemble the lower panel provided in the kit to the unit with the (2) No. 8-32 X2–1/4 inches long screws and retaining washers.
7. Install the ice lift out tray and cup rest in the drip tray. The unit is now ready for operation.

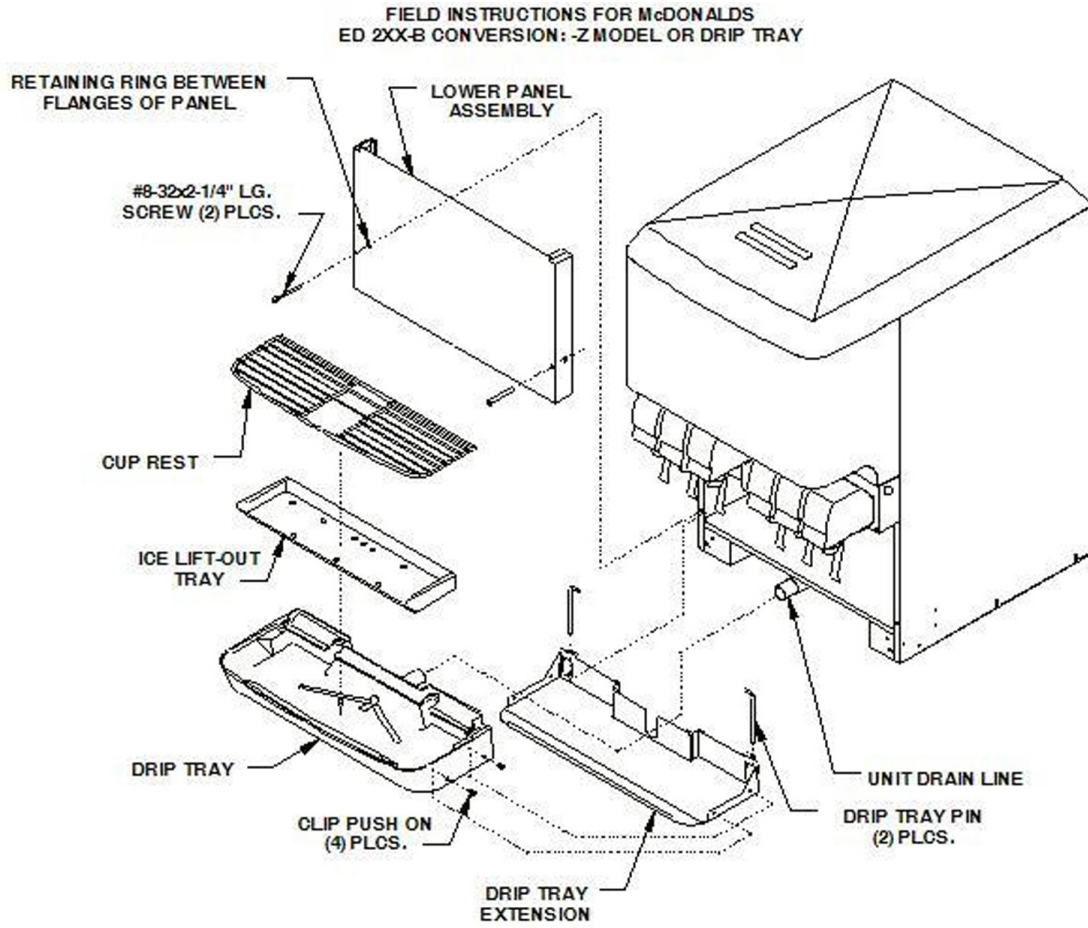

Figure 1. Parts Identification

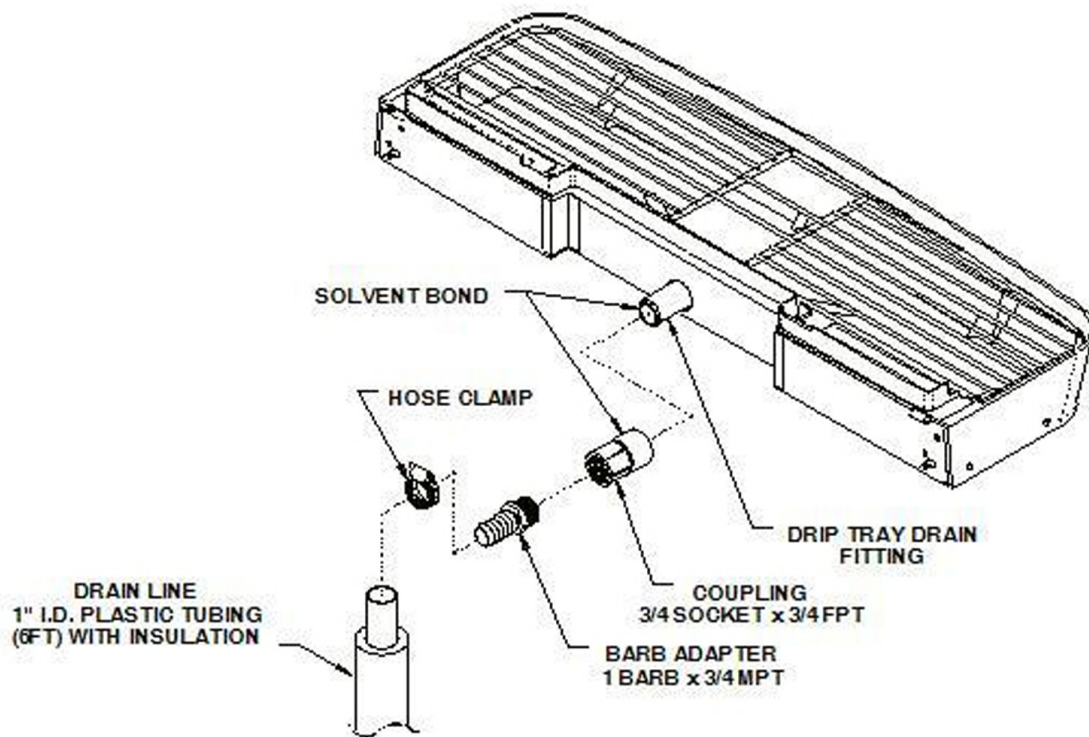

Figure 2. Drip Tray Drain Hook-Up