

# INSTALLATION INSTRUCTIONS

## ED2XX "K" STYLE LID KITS, P/N: 08034TE, 08055TE

### SAFETY INSTRUCTIONS

**WARNING:**

Before starting installation, read and understand all safety label and warnings on the machine. Also review and understand all safety instructions in the owners, installation and service manuals.

**Failure to comply could result in serious injury, death or damage to the equipment.**

### QUALIFIED SERVICE PERSONNEL

**WARNING:**

Only trained and certified electrical, plumbing and refrigeration technicians should service this unit.

**All wiring and plumbing must conform to national and local codes. Failure to comply could result in serious injury, death or equipment damage.**

### SAFETY PRECAUTIONS

**WARNING:**

Disconnect power to the unit before servicing. Follow all lock out/tag out procedures established by the user. Verify all power is off to the unit before performing any work.

**Failure to comply could result in serious injury, death or damage to the equipment.**

**CAUTION:**

Always be sure to keep the area around the unit clean and free of clutter.

**Failure to keep this area clean may result in injury or equipment damage.**

## Kit includes:

**Table 1. Loose shipped Parts List**

Item No.	Part No.	Description	Quantity
1	620200136	Lid and Lanyard Assembly, Gray - 08055TE	1
	620200134	Lid and Lanyard Assembly, Black - 08034TE	
2	15276	Lid Assembly	1
3	22127	Bracket	2
4	70217	#8 Screw	12
5	50904	RTV	1
6	90221	Label	1
7	08034TEINS	Installation Instruction	1
8	620701902	Acorn Nut, 8-32 Nylon	2
9	620701901	Sealing Washer	2
10	620037003	Ice Baffle ED2XX	1
11	621701903	#8 Nylon Washer	2
12	43164	Screw MA 08-32 TRPH 10 SS	2
13	70100	Nut HEX 08-32 SS Nylok	2

### Instructions for Installation of The ED2XX "K" Style Lid.

1. Unpack Kit.
2. Insert baffle assembly into the adapter lid.
3. Place (2) sealing washers (item 9) over studs and (2) flat washers (item 11), then fasten in place with (2) plastic acorn nuts (item 8).
4. Set ice maker lid on the top of the dispenser.
5. Using the slotted holes in the lid as a template, drill four (4) .140IN diameter (9/64IN) holes at the bottom of the slots (see View A in Figure 1). Use extreme care not to drill into the hopper. Fasten the lid to the dispenser with four (4) #8 sheet metal screws, two on each side.
6. Seal the ice maker to the top of the dispenser as follows:
  - A. Run beads of RTV around the opening in the lid and inside of the perimeter of the ice maker outline so that the ice maker will set on the RTV.
  - B. Set the ice maker onto the lid and position it as required.
  - C. Wipe away the excess RTV.
7. Drill 9/64" diameter holes into the ice maker cabinet using the bracket as a template. Use extreme care not to drill into any ice maker components (condenser, tubing, etc.). Secure the brackets using the screws provided.
8. Follow the ice maker manufacturers instruction to complete the installation of the ice maker including the bin thermostat if so equipped or required.
9. If the plastic acorn nuts interfere with the positioning of the plastic manual fill cover, it may be necessary to make small notches in the back flange of the cover to clear the acorn nuts.

**NOTE: Bin Thermostat must not interfere with the agitator rotation.**

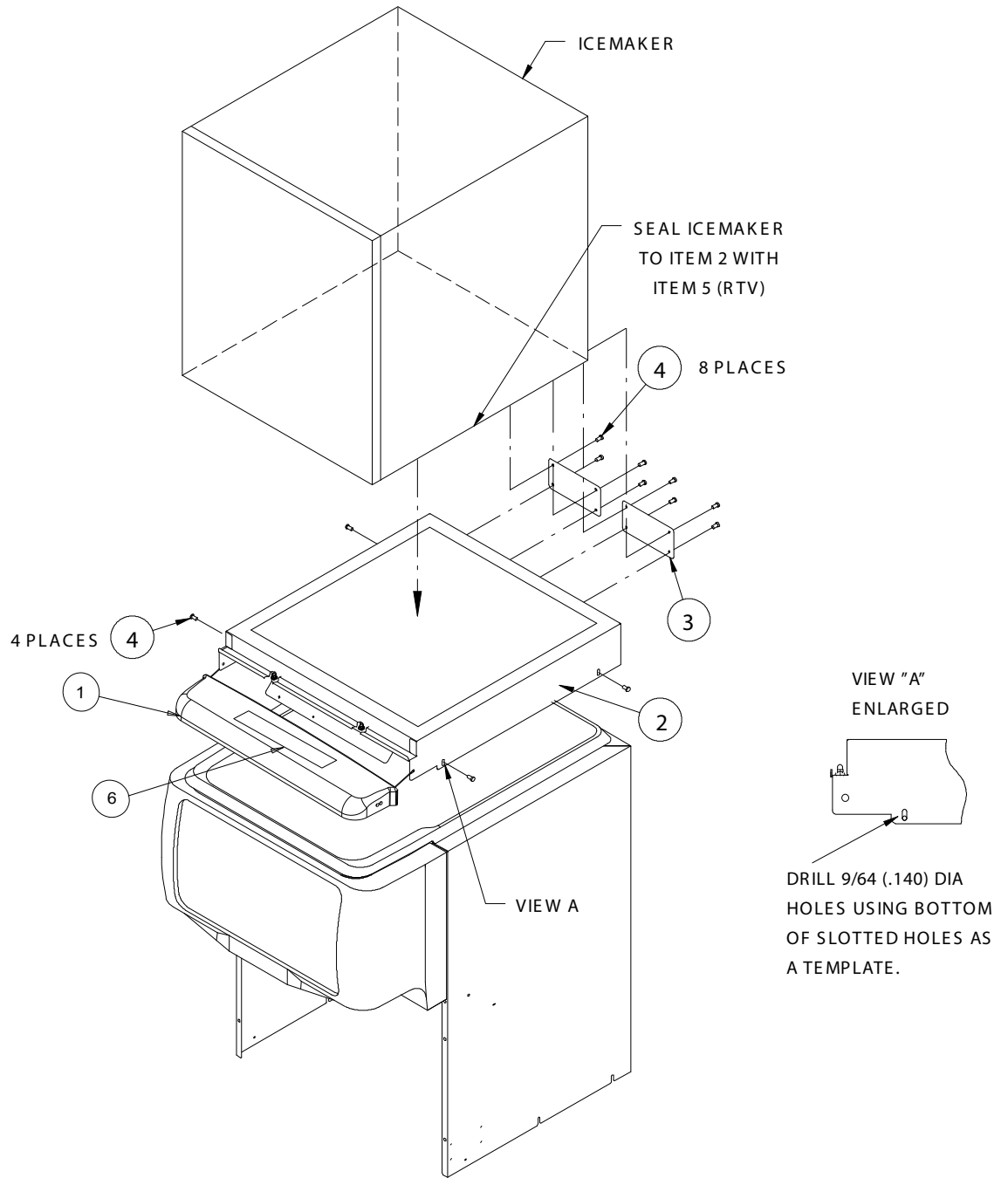

**Figure 1. ED2XX KIT**

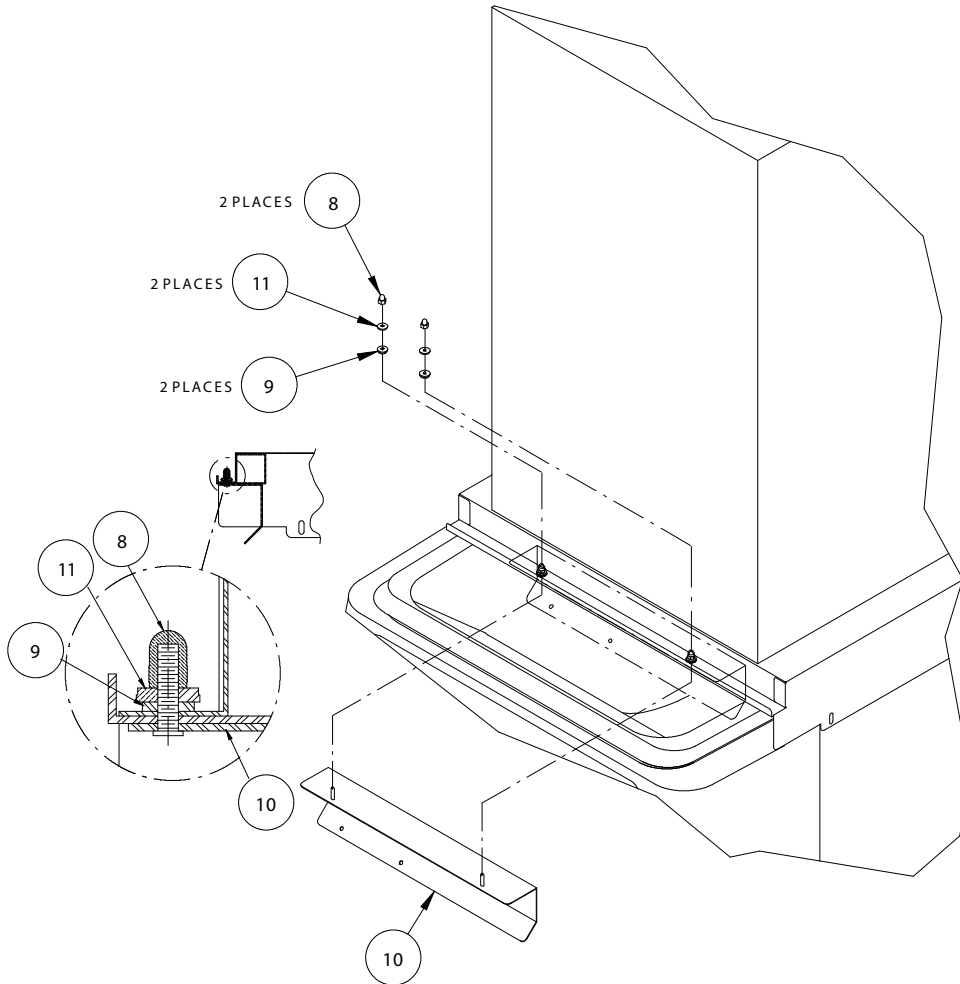

Figure 2. ED2XX KIT

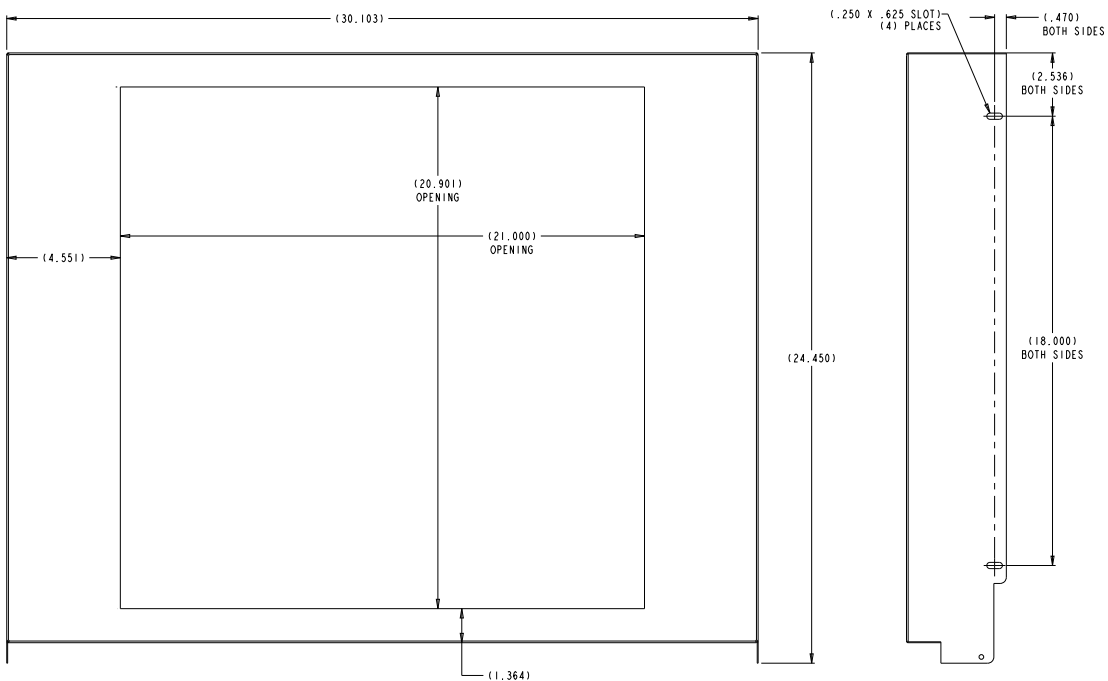

Figure 3. Reference Sheetmetal Cover Opening Dimensions for Mounting Icemaker.