

INSTALLATION INSTRUCTIONS

"K" STYLE LID KIT, P/N 630000085

These "K" style kits apply to the following ice makers and are for use with DF/ED 200/250 dispensers:

Table 1. Applicable Models

Ice Maker	Size
Hoshizaki KM250/450/500/630/650	22"

Table 2. Loose Shipped Parts

Item No.	Part No.	Name	Qty.
1	630000310	Lid Assembly, "K" Style	1
2	15303	Bracket	1
3	50904	RTV, Clear, 732, 3 oz. Tube	1
4	630000311	Cover, RH Assembly	1
5	70217	#8 Sheet Metal Screw	6
6	90221	Label, <i>Disconnect Before Cleaning</i>	1
7	70188	Thumb Screw #8-32 x 1/2"	1
8	630460040	Installation Instruction	1
9	22127	Bracket, LS Mounting	1



WARNING:

Disconnect power to the unit before installing the adaptor following all lockout/tag out procedures established by the user. Verify that all the power is off to the unit before performing any work.

Failure to comply could result in serious injury, death or damage to the equipment.



WARNING:

All ice baffle plates and bin stats, if included or recommended in this kit, must be installed as directed in this manual or the equipment manufacturer's instructions.

Failure to comply could result in serious injury, death or damage to the equipment.



WARNING:

All of the attachment screws and plates must be installed as directed in this manual.

Failure to comply could result in serious injury, death or damage to the equipment.

1. Set Ice maker lid on the top of the dispenser and position it flush with the back and sides of the dispenser.
2. Using the slotted holes in the lid as a template, drill four (4) 0.140" diameter holes at the bottom of the slots (see Detail A, Figure 1). Use extreme care not to drill into the hopper. Fasten the lid to the dispenser with four (4) #8 sheet metal screws, two on each side.
3. Seal the ice maker to the top of the dispenser as follows:
 - A. Apply beads of RTV around the opening in the lid and inside the perimeter of the ice maker outline so that the ice maker will set on the RTV.
 - B. Set the ice maker onto the lid and position it as required.
 - C. Wipe away any excess RTV.
4. Remove the two rear screws (only) installed in step 2. Use those screws to install the mounting brackets (item 2 and/or item 9). Drill 9/64" diameter holes into the ice maker cabinet using the bracket as a template. Use extreme caution not to drill into any ice maker components (condenser, tubing, etc.). Secure the brackets using the screws provided.

5. Follow the ice maker manufacturers instruction to complete the installation of the ice maker including the bin thermostat if so equipped or required.

Note: Bin thermostat must not interfere with agitator rotation.

Note: The back of the ice maker must be flush with the back of the lid (item 1).

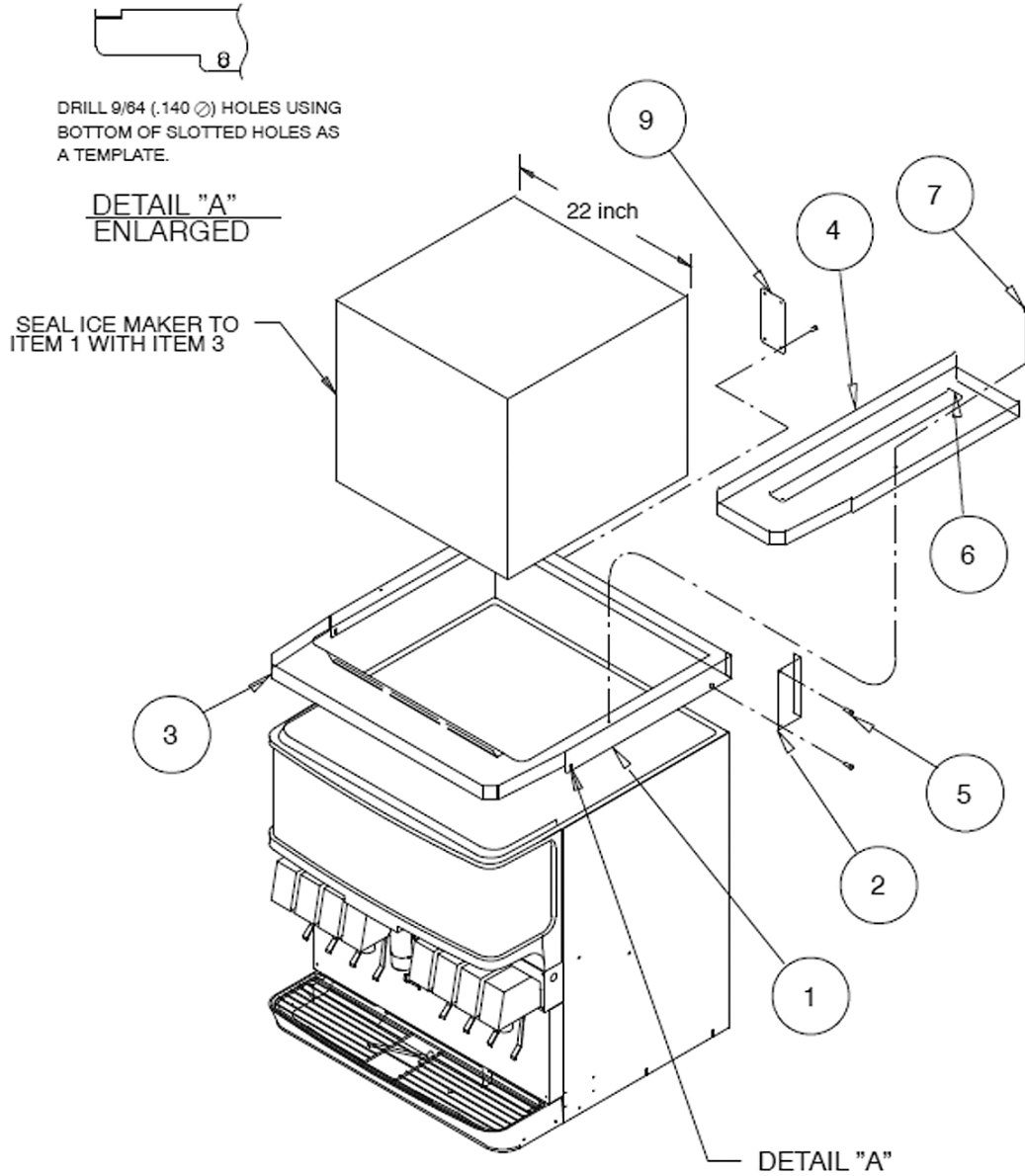

Figure 1.