



VIPER™

Viper™

3 Flavor Frozen Dispenser - Tall

Specification Guide



## Features

### High Capacity

Surge capacity dispensing 10 (16oz) consecutive drinks per barrel with a continuous draw capacity of 75-82 fl.oz per minute

### Patented Intelligent Defrost™

Manages product quality and bypasses unnecessary defrost times

### Defrost Lock-Out Times

Schedule defrost lockout times to avoid down time during peak demand periods

### Sleep Mode

Schedule sleep modes to conserve energy during off hours

### Remote Condenser

Remote and air-cooled condenser options available

### QR Code

Quickly access service manuals and easy-to-follow training videos

### C3 Technology

Cooling, carbonation, and controls provide unmatched drink profile consistency and minimizes syrup usage

### Serviceability

Reduced maintenance and service times with a 0.3% out of the box failure rate

### Programmable Flavor Barrels

Individual barrel flexibility and profile settings

### ADA Compliant

Stainless push handle valve



MARMON  
Foodservice  
Technologies

A BERKSHIRE HATHAWAY COMPANY



Viper™

# 3 Flavor Frozen Dispenser - Tall

Specification Guide

## Technical Specifications

<b>Electrical Requirements</b>	230V +/- 15V 60Hz, 30a, Single Phase 230V +/- 15v 50Hz, 30a, Single Phase
	<i>Includes 8ft. power NEMA L6-30P molded plug connection. Part Numbers ending in "EU" and 50HZ SKUs include 8ft. power cord IEC60309 32Amp molded plug connections - Part numbers ending in "AU" include 56PA332 plug</i>
<b>Pressure Requirements</b>	CO2 = 75 psig Water = 25 min psig dynamic
<b>Draw Capacity</b>	75-82 oz/min continuous, alternating barrels @ 75° F (24°C)
<b>Refrigeration</b>	19,000 BTU, R448A
<b>Minimum Clearance Requirements</b>	Top: 12" (305mm) Both Sides: 2" (51mm) -or- Back: 2" (51mm) for temperatures < 90°F (32°C)
<b>Unit Dimensions</b>	22.75"W x 32.5"D x 43.7"H (577.85mm x 825.5mm x 19.8mm)
<b>Graphic Card Dimensions</b>	22.5"W x 18.75"H (571.5mm x 8.5mm)
<b>Flavor Card Dimensions</b>	6.5"W x 4"H (165.1mm x 101.6mm)
<b>Unit Weight</b>	445lbs (201.8kg)
<b>Shipping Weight</b>	Unit: 465lbs (210.92kg) Cart: 175lbs (79.39kg)
<b>Agency Listing</b>	60 Hz 50 Hz

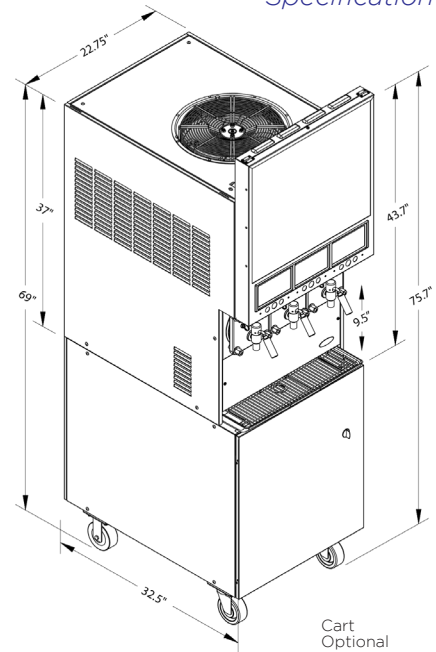

Cart Optional

Model Number	Description
621366142	Viper 3 Barrel, 60Hz, R448A, Air Cooled, Stainless Push Handle Valve (SPH), Tall Merchandiser, N. American Power Cord
621366042	Viper 3 Barrel, 60Hz, R448A, Air Cooled, Motorman Valve, Tall Merchandiser, N. American Power Cord

*Not all configurations are available - please contact a Cornelius® expert for additional information  
For FUB, Motorman Valves are recommended  
Note: When ordering the **Remote Condensing Dispenser**, the corresponding accessory below (marked with!) must also be ordered. Additionally, one of the 2 line set options (marked with\*\*) must also be ordered*

Accessories Number	Description
629087406	Leg kit, 4" legs adjustable to 5.25"
620053990	Viper 3 barrel cart, stainless steel
620046410	Viper 3 barrel generic graphic for tall merchandiser
620042868	Generic flavor card set (includes 18 flavors)
620051378	Coke flavor card set
620051379	Pepsi flavor card set
620067479	Pre-wired buck boost transformer
620067108	Remote condenser unit!
620071967	50ft Line Set (1) 3/8" and (1) 1/2"***
620071969	100ft Line Set (1) 3/8" (1) 1/2"*
629096928	Viper 3 barrel installation kit
621058482	Viper 3 barrel pre-plumbed cart
326002000	Drain kit for drip tray

*Refer to Installation Manual for required installation materials - A Buck/Boost transformer is recommended for most installations  
Note: When ordering the **Remote Condensing Dispenser**, the corresponding accessory above (marked with!) must also be ordered. Additionally, one of the 2 line set options (marked with\*\*) must also be ordered.*

To learn more and see **Viper™** in action, visit [cornelius.com](http://cornelius.com)  
To contact a Cornelius® expert today, visit [cornelius.com/contact-us](http://cornelius.com/contact-us)