



Viper™ Elite Classic

4 Flavor Frozen Dispenser - Tall

Specification Guide

VIPER™ ELITE CLASSIC



Features

Enhanced Reliability

Increase uptime with the most reliable FCB dispenser on the market

Syrup Flexibility

Pressure transducers ensure you'll be able to perform as syrups change in the future

Expand Drink Portfolio

Individual barrel flexibility (FCB/FUB) and profile settings

Intelligent Defrost™

Patented adaptive defrost keeps you up and running during peak demand so you never miss a sale

Remote Option

Remote and air-cooled condenser options available

Information At Your Fingertips

Quickly access manuals and easy-to-follow staff and service videos via QR code

C3 Technology

Cooling, carbonation, and controls provide unmatched drink profile consistency, builds repeat sales and minimizes syrup usage

Programmable Sleep Mode

Conserves energy in off hours

Technician Designed

Reduced maintenance and service times

ADA Compliant

Stainless push handle valve



MARMON
Foodservice
Technologies

A BERKSHIRE HATHAWAY COMPANY



Viper™ Elite Classic

4 Flavor Frozen Dispenser - Tall

Specification Guide

Technical Specifications

| | |
|---|--|
| Electrical Requirements | 230V +/- 15V 60Hz, 30a, single phase <i>Includes 8ft. power NEMA L6-30P molded plug connection. Part Numbers ending in "EU" and 50HZ SKU's include 8ft. power cord IEC60309 32Amp molded plug connections</i> |
| Pressure Requirements | CO2 = 75 psig Water = 25 min psig dynamic |
| Draw Capacity | 75-82 oz/min continuous, alternating barrels @ 75° F ambient |
| Refrigeration | 19,000 BTU, R404A |
| Agency Listing |   |
| Clearing Requirements | Top: 12" Sides: 2" OR Back: 2" <i>The above dimensions are minimum unit clearance requirements</i> |
| Dispenser Unit Dimensions | 29"W x 32.5"D x 43.7"H |
| Unit Weight | 475lbs |
| Remote Condenser Unit Dimensions | 38.25" W X 32.23" D X 27.60" H |
| Remote Condenser Operating Temperature | -20°F to 120°F |
| Graphic Card Dimensions | 28.75"W x 18.75"H |
| Flavor Card Dimensions | 6.5"W x 4"H |
| Shipping Weight | Unit: 500 lbs Cart: 200 lbs Remote Condenser: 180 lbs |

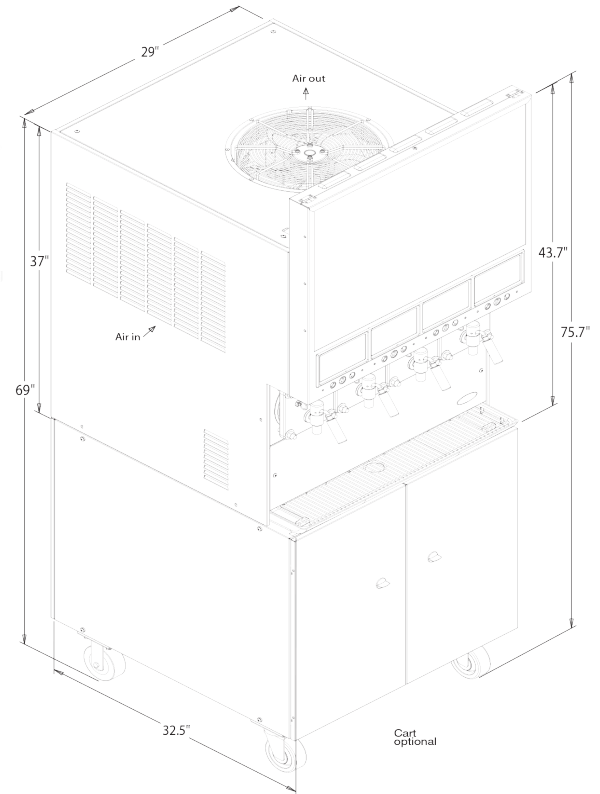

| Model Number | Description |
|--------------|---|
| 621460142 | Viper Elite Classic 4 flavor, 230/60Hz, SPH Valve, Tall Merchandiser |
| 621460042 | Viper Elite Classic 4 flavor, 230/60Hz, Motorman Valve, Tall Merchandiser |
| 621462142 | Viper Elite Classic Remote 4 flavor, 230/60Hz, SPH Valve* |

***Note: When ordering the Remote unit, the corresponding condenser accessory below (marked with*) must also be ordered. Additionally, one of the 2 line set options (marked with**) must be ordered.**
SPH stands for Stainless Push Handle. For FUB applications, Motorman valves are recommended

| Accessories Number | Description |
|--------------------|--|
| 629087406 | Leg kit, 4" legs adjustable to 5.25" |
| 620046556 | Viper 4 flavor cart, stainless steel |
| 620046477 | Viper 4 flavor generic graphic for tall merchandiser |
| 620042868 | Generic flavor card set (includes 18 flavors) |
| 620067479 | Pre-wired Buck Boost Transformer |
| 620067108 | Viper 3 flavor & Viper 4 flavor remote condenser unit for tall merchandiser* |
| 620071967 | 50ft Line Set (1) 3/8" and (1) 1/2"*** |
| 620071969 | 100ft Line Set (1) 3/8" (1) 1/2"*** |
| 326002000 | Drain kit for drip tray |

Refer to Installation Manual for required installation materials

To learn more and see **Viper™ Elite Classic** in action, visit cornelius.com

To contact us directly, go to cornelius.com/contact-us