



VIPER™

Viper™

3 Flavor Frozen Dispenser - Tall

Specification Guide



## Features

### High Capacity

Surge capacity dispensing 10 (16oz) consecutive drinks per barrel with a continuous draw capacity of 75-82 fl.oz per minute

### Patented Intelligent Defrost™

Manages product quality and bypasses unnecessary defrost times

### Defrost Lock-Out Times

Schedule defrost lockout times to avoid down time during peak demand periods

### Sleep Mode

Schedule sleep modes to conserve energy during off hours

### Remote Condenser

Remote and air-cooled condenser options available

### QR Code

Quickly access service manuals and easy-to-follow training videos

### C3 Technology

Cooling, carbonation, and controls provide unmatched drink profile consistency and minimizes syrup usage

### Serviceability

Reduced maintenance and service times with a 0.3% out of the box failure rate

### Programmable Flavor Barrels

Individual barrel flexibility and profile settings

### ADA Compliant

Stainless push handle valve



MARMON  
Foodservice  
Technologies

A BERKSHIRE HATHAWAY COMPANY



Viper™

# 3 Flavor Frozen Dispenser - Tall

Specification Guide

## Technical Specifications

<b>Electrical Requirements</b>	230V +/- 15V 60Hz, 30a, Single Phase 230V +/- 15v 50Hz, 30a, Single Phase
	<i>Includes 8ft. power NEMA L6-30P molded plug connection. Part Numbers ending in "EU" and 50HZ SKU's include 8ft. power cord IEC60309 32Amp molded plug connections - Part numbers ending in "AU" include 56PA332 plug</i>
<b>Pressure Requirements</b>	CO2 = 75 psig Water = 25 min psig dynamic
<b>Draw Capacity</b>	75-82 oz/min continuous, alternating barrels @ 75° F (24°C)
<b>Refrigeration</b>	19,000 BTU, R404A
<b>Minimum Clearance Requirements</b>	Top: 12" (305mm) Both Sides: 2" (51mm) -or- Back: 2" (51mm) for temperatures < 90°F (32°C)
<b>Unit Dimensions</b>	22.75"W x 32.5"D x 43.7"H (577.85mm x 825.5mm x 19.8mm)
<b>Graphic Card Dimensions</b>	22.5"W x 18.75"H (571.5mm x 8.5mm)
<b>Flavor Card Dimensions</b>	6.5"W x 4"H (165.1mm x 101.6mm)
<b>Unit Weight</b>	445lbs (201.8kg)
<b>Shipping Weight</b>	Unit: 465lbs (210.92kg) Cart: 175lbs (79.39kg)
<b>Agency Listing</b>	60 Hz
	50 Hz

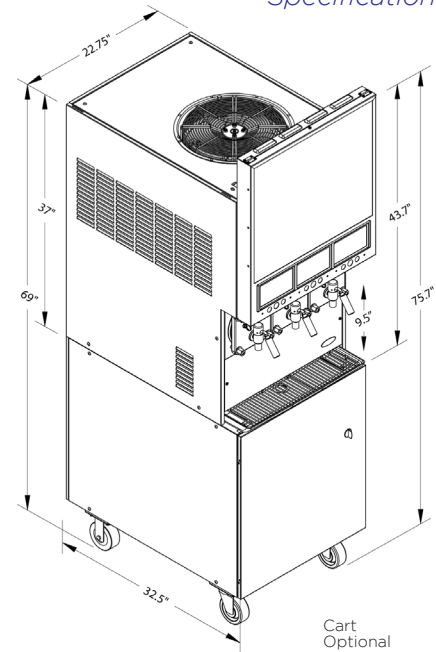

Model Number	Description
621360142	Viper 3 Barrel, 60Hz, R404A, Air Cooled, Stainless Push Handle Valve (SPH), Tall Merchandiser, N. American Power Cord
621360042	Viper 3 Barrel, 60Hz, R404A, Air Cooled, Motorman Valve, Tall Merchandiser, N. American Power Cord
621350042	Viper 3 Barrel, 50Hz, R404A, Air Cooled, Motorman Valve, Tall Merchandiser, IEC Power Cord
621360142EU	Viper 3 Barrel, 60Hz, R404A, Air Cooled, Motorman Valve, Tall Merchandiser, IEC Power Cord
621362142	Viper 3 Barrel, 60Hz, R404A, Remote Condensing Dispenser, Stainless Push Handle Valve (SPH), Tall Merchandiser, N. American Power Cord*

Not all configurations are available – please contact a Cornelius® expert for additional information

For FUB, Motorman Valves are recommended

Note: When ordering the **Remote Condensing Dispenser**, the corresponding accessory below (marked with†) must also be ordered. Additionally, one of the 2 line set options (marked with\*\*) must also be ordered

This equipment is **prohibited** from use in California in accordance with the **California Code of Regulations, title 17, section 95374** and in Colorado, Delaware, Maryland, Massachusetts, New Jersey, New York, Vermont, and Washington and is expected to be prohibited in Virginia by July 1, 2021. This disclosure statement has been reviewed and approved by Marmon Foodservice Technologies, and Marmon Foodservice Technologies attests, under penalty of perjury, that these statements are true and accurate. Consider Viper™ equipment with R448A refrigerant, if available.

Accessories Number	Description
629087406	Leg kit, 4" legs adjustable to 5.25"
620053990	Viper 3 barrel cart, stainless steel
620046410	Viper 3 barrel generic graphic for tall merchandiser
620042868	Generic flavor card set (includes 18 flavors)
620051378	Coke flavor card set
620051379	Pepsi flavor card set
620067479	Pre-wired buck boost transformer
620067108	Remote condenser unit†
620071967	50ft Line Set (1) 3/8" and (1) 1/2"***
620071969	100ft Line Set (1) 3/8" (1) 1/2"**
629096928	Viper 3 barrel installation kit
621058482	Viper 3 barrel pre-plumbed cart
326002000	Drain kit for drip tray

Refer to Installation Manual for required installation materials - A Buck/Boost transformer is recommended for most installations

Note: When ordering the **Remote Condensing Dispenser**, the corresponding accessory above (marked with†) must also be ordered. Additionally, one of the 2 line set options (marked with\*\*) must also be ordered.

To learn more and see **Viper™** in action, visit [cornelius.com](http://cornelius.com)  
To contact a Cornelius® expert today, visit [cornelius.com/contact-us](http://cornelius.com/contact-us)