



Viper™

4 Flavor Frozen Dispenser - **Short**

Specification Guide

VIPER™



## Features

### High Capacity

Surge capacity dispensing 10 (16oz) consecutive drinks per barrel with a continuous draw capacity of 75-82 fl.oz per minute

### Patented Intelligent Defrost™

Manages product quality and bypasses unnecessary defrost times

### Defrost Lock-Out Times

Schedule defrost lockout times to avoid down time during peak demand periods

### Sleep Mode

Schedule sleep modes to conserve energy during off hours

### Remote Condenser

Remote and air-cooled condenser options available

### QR Code

Quickly access service manuals and easy-to-follow training videos

### C3 Technology

Cooling, carbonation, and controls provide unmatched drink profile consistency and minimizes syrup usage

### Serviceability

Reduced maintenance and service times with a 0.3% out of the box failure rate

### Programmable Flavor Barrels

Individual barrel flexibility and profile settings

### ADA Compliant

Stainless push handle valve



MARMON  
Foodservice  
Technologies

A BERKSHIRE HATHAWAY COMPANY





Viper™

# 4 Flavor Frozen Dispenser - Short

Specification Guide

## Technical Specifications

<b>Electrical Requirements</b>	230V +/- 15V 60Hz, 30a, single phase <i>Includes 8ft. power NEMA L6-30P molded plug connection. Part Numbers ending in "EU" SKU's include 8ft. power cord IEC60309 32Amp molded plug connections</i>
<b>Pressure Requirements</b>	CO2 = 75 psig    Water = 25 min psig dynamic
<b>Draw Capacity</b>	75-82 oz/min continuous, alternating barrels @ 75° F (24°C)
<b>Refrigeration</b>	19,000 BTU, R448A
<b>Minimum Clearance Requirements</b>	Top: 12" (305mm)    Both Sides: 2" (51mm) -or- Back: 2" (51mm) <i>for temperatures &lt; 90°F (32°C)</i>
<b>Unit Dimensions</b>	29"W x 32.5"D x 37"H (577.85mm x 825.5mm x 939.8mm)
<b>Graphic Card Dimensions</b>	28.75"W x 11.79"H (730.25mm x 299.5mm)
<b>Flavor Card Dimensions</b>	6.5"W x 4"H (165.1mm x 101.6mm)
<b>Unit Weight</b>	470lbs (213.2kg)
<b>Shipping Weight</b>	Unit: 500lbs (226.8kg)    Cart: 200lbs (90.72kg)
<b>Agency Listing</b>	 

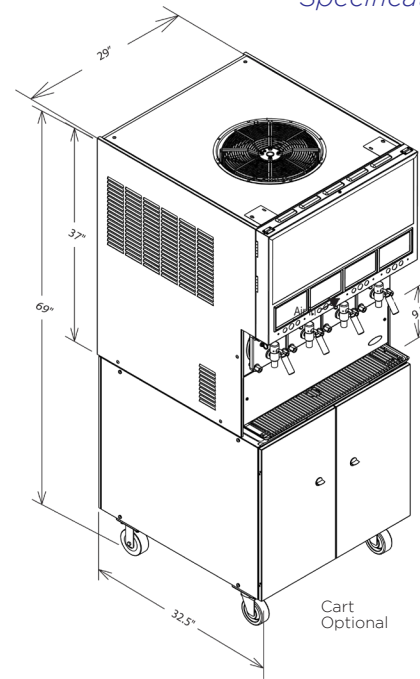

Model Number	Description
621466141	Viper 4 Barrel, 60Hz, R448A, Air Cooled, Stainless Push Handle Valve (SPH), Short Merchandiser, N. American Power Cord
621466041	Viper 4 Barrel, 60Hz, R448A, Air Cooled, Motorman Valve, Short Merchandiser, N. American Power Cord

*Not all configurations are available - please contact a Cornelius® expert for additional information  
For FUB, Motorman Valves are recommended*

Accessories Number	Description
629087406	Leg kit, 4" legs adjustable to 5.25"
620046556	Viper 4 barrel cart, stainless steel
620047323	Viper 4 barrel generic graphic for short merchandiser
620042868	Generic flavor card set (includes 18 flavors)
620051378	Coke flavor card set
620051379	Pepsi flavor card set
620067479	Pre-wired buck boost transformer
629096929	Viper 4 barrel installation kit
326002000	Drain kit for drip tray

*Refer to Installation Manual for required installation materials - A Buck/Boost transformer is recommended for most installations*

To learn more and see **Viper™** in action, visit [cornelius.com](http://cornelius.com)  
To contact a Cornelius® expert today, visit [cornelius.com/contact-us](http://cornelius.com/contact-us)